

ENGINE

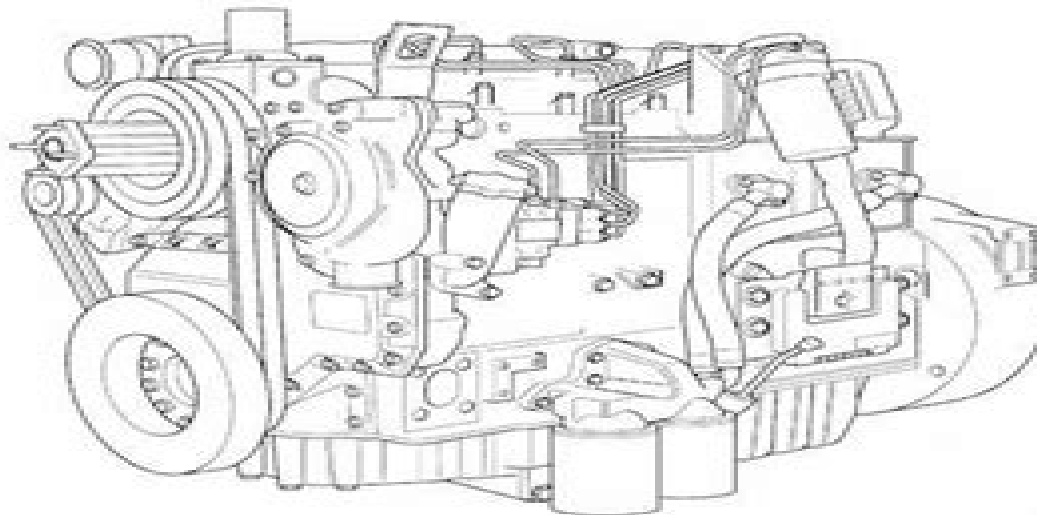

SERVICE MANUAL

Perkins®
1100 Series 6-Cylinder Diesel Engine



Manual Perkins 6 Cilindros

Mike Jess



Manual Perkins 6 Cilindros:

Embark on a transformative journey with Explore the World with is captivating work, **Manual Perkins 6 Cilindros** . This enlightening ebook, available for download in a convenient PDF format Download in PDF: , invites you to explore a world of boundless knowledge. Unleash your intellectual curiosity and discover the power of words as you dive into this riveting creation. Download now and elevate your reading experience to new heights .

<https://www.splashdogs.com/About/uploaded-files/default.aspx/Isuzu%20Rodeo%202001%20Repair%20Service%20Manual.pdf>

Table of Contents Manual Perkins 6 Cilindros

1. Understanding the eBook Manual Perkins 6 Cilindros
 - The Rise of Digital Reading Manual Perkins 6 Cilindros
 - Advantages of eBooks Over Traditional Books
2. Identifying Manual Perkins 6 Cilindros
 - Exploring Different Genres
 - Considering Fiction vs. Non-Fiction
 - Determining Your Reading Goals
3. Choosing the Right eBook Platform
 - Popular eBook Platforms
 - Features to Look for in an Manual Perkins 6 Cilindros
 - User-Friendly Interface
4. Exploring eBook Recommendations from Manual Perkins 6 Cilindros
 - Personalized Recommendations
 - Manual Perkins 6 Cilindros User Reviews and Ratings
 - Manual Perkins 6 Cilindros and Bestseller Lists
5. Accessing Manual Perkins 6 Cilindros Free and Paid eBooks
 - Manual Perkins 6 Cilindros Public Domain eBooks
 - Manual Perkins 6 Cilindros eBook Subscription Services

- Manual Perkins 6 Cilindros Budget-Friendly Options
- 6. Navigating Manual Perkins 6 Cilindros eBook Formats
 - ePub, PDF, MOBI, and More
 - Manual Perkins 6 Cilindros Compatibility with Devices
 - Manual Perkins 6 Cilindros Enhanced eBook Features
- 7. Enhancing Your Reading Experience
 - Adjustable Fonts and Text Sizes of Manual Perkins 6 Cilindros
 - Highlighting and Note-Taking Manual Perkins 6 Cilindros
 - Interactive Elements Manual Perkins 6 Cilindros
- 8. Staying Engaged with Manual Perkins 6 Cilindros
 - Joining Online Reading Communities
 - Participating in Virtual Book Clubs
 - Following Authors and Publishers Manual Perkins 6 Cilindros
- 9. Balancing eBooks and Physical Books Manual Perkins 6 Cilindros
 - Benefits of a Digital Library
 - Creating a Diverse Reading Collection Manual Perkins 6 Cilindros
- 10. Overcoming Reading Challenges
 - Dealing with Digital Eye Strain
 - Minimizing Distractions
 - Managing Screen Time
- 11. Cultivating a Reading Routine Manual Perkins 6 Cilindros
 - Setting Reading Goals Manual Perkins 6 Cilindros
 - Carving Out Dedicated Reading Time
- 12. Sourcing Reliable Information of Manual Perkins 6 Cilindros
 - Fact-Checking eBook Content of Manual Perkins 6 Cilindros
 - Distinguishing Credible Sources
- 13. Promoting Lifelong Learning
 - Utilizing eBooks for Skill Development
 - Exploring Educational eBooks
- 14. Embracing eBook Trends

- Integration of Multimedia Elements
- Interactive and Gamified eBooks

Manual Perkins 6 Cilindros Introduction

Free PDF Books and Manuals for Download: Unlocking Knowledge at Your Fingertips In today's fast-paced digital age, obtaining valuable knowledge has become easier than ever. Thanks to the internet, a vast array of books and manuals are now available for free download in PDF format. Whether you are a student, professional, or simply an avid reader, this treasure trove of downloadable resources offers a wealth of information, conveniently accessible anytime, anywhere. The advent of online libraries and platforms dedicated to sharing knowledge has revolutionized the way we consume information. No longer confined to physical libraries or bookstores, readers can now access an extensive collection of digital books and manuals with just a few clicks. These resources, available in PDF, Microsoft Word, and PowerPoint formats, cater to a wide range of interests, including literature, technology, science, history, and much more. One notable platform where you can explore and download free Manual Perkins 6 Cilindros PDF books and manuals is the internet's largest free library. Hosted online, this catalog compiles a vast assortment of documents, making it a veritable goldmine of knowledge. With its easy-to-use website interface and customizable PDF generator, this platform offers a user-friendly experience, allowing individuals to effortlessly navigate and access the information they seek. The availability of free PDF books and manuals on this platform demonstrates its commitment to democratizing education and empowering individuals with the tools needed to succeed in their chosen fields. It allows anyone, regardless of their background or financial limitations, to expand their horizons and gain insights from experts in various disciplines. One of the most significant advantages of downloading PDF books and manuals lies in their portability. Unlike physical copies, digital books can be stored and carried on a single device, such as a tablet or smartphone, saving valuable space and weight. This convenience makes it possible for readers to have their entire library at their fingertips, whether they are commuting, traveling, or simply enjoying a lazy afternoon at home. Additionally, digital files are easily searchable, enabling readers to locate specific information within seconds. With a few keystrokes, users can search for keywords, topics, or phrases, making research and finding relevant information a breeze. This efficiency saves time and effort, streamlining the learning process and allowing individuals to focus on extracting the information they need. Furthermore, the availability of free PDF books and manuals fosters a culture of continuous learning. By removing financial barriers, more people can access educational resources and pursue lifelong learning, contributing to personal growth and professional development. This democratization of knowledge promotes intellectual curiosity and empowers individuals to become lifelong learners, promoting progress and innovation in various fields. It is worth noting that while accessing free Manual Perkins 6 Cilindros PDF books and manuals is convenient and cost-effective, it is vital to respect

copyright laws and intellectual property rights. Platforms offering free downloads often operate within legal boundaries, ensuring that the materials they provide are either in the public domain or authorized for distribution. By adhering to copyright laws, users can enjoy the benefits of free access to knowledge while supporting the authors and publishers who make these resources available. In conclusion, the availability of Manual Perkins 6 Cilindros free PDF books and manuals for download has revolutionized the way we access and consume knowledge. With just a few clicks, individuals can explore a vast collection of resources across different disciplines, all free of charge. This accessibility empowers individuals to become lifelong learners, contributing to personal growth, professional development, and the advancement of society as a whole. So why not unlock a world of knowledge today? Start exploring the vast sea of free PDF books and manuals waiting to be discovered right at your fingertips.

FAQs About Manual Perkins 6 Cilindros Books

What is a Manual Perkins 6 Cilindros PDF? A PDF (Portable Document Format) is a file format developed by Adobe that preserves the layout and formatting of a document, regardless of the software, hardware, or operating system used to view or print it. **How do I create a Manual Perkins 6 Cilindros PDF?** There are several ways to create a PDF: Use software like Adobe Acrobat, Microsoft Word, or Google Docs, which often have built-in PDF creation tools. Print to PDF: Many applications and operating systems have a "Print to PDF" option that allows you to save a document as a PDF file instead of printing it on paper. Online converters: There are various online tools that can convert different file types to PDF. **How do I edit a Manual Perkins 6 Cilindros PDF?** Editing a PDF can be done with software like Adobe Acrobat, which allows direct editing of text, images, and other elements within the PDF. Some free tools, like PDFescape or Smallpdf, also offer basic editing capabilities. **How do I convert a Manual Perkins 6 Cilindros PDF to another file format?** There are multiple ways to convert a PDF to another format: Use online converters like Smallpdf, Zamzar, or Adobe Acrobats export feature to convert PDFs to formats like Word, Excel, JPEG, etc. Software like Adobe Acrobat, Microsoft Word, or other PDF editors may have options to export or save PDFs in different formats. **How do I password-protect a Manual Perkins 6 Cilindros PDF?** Most PDF editing software allows you to add password protection. In Adobe Acrobat, for instance, you can go to "File" -> "Properties" -> "Security" to set a password to restrict access or editing capabilities. Are there any free alternatives to Adobe Acrobat for working with PDFs? Yes, there are many free alternatives for working with PDFs, such as: LibreOffice: Offers PDF editing features. PDFsam: Allows splitting, merging, and editing PDFs. Foxit Reader: Provides basic PDF viewing and editing capabilities. How do I compress a PDF file? You can use online tools like Smallpdf, ILovePDF, or desktop software like Adobe Acrobat to compress PDF files without significant quality loss. Compression reduces the file size, making it easier

to share and download. Can I fill out forms in a PDF file? Yes, most PDF viewers/editors like Adobe Acrobat, Preview (on Mac), or various online tools allow you to fill out forms in PDF files by selecting text fields and entering information. Are there any restrictions when working with PDFs? Some PDFs might have restrictions set by their creator, such as password protection, editing restrictions, or print restrictions. Breaking these restrictions might require specific software or tools, which may or may not be legal depending on the circumstances and local laws.

Find Manual Perkins 6 Cilindros :

[isuzu rodeo 2001 repair service manual](#)

[isuzu gemini manual](#)

[itunes producer user guide](#)

isuzu wizard manual gemini

itaposs so easy book

it essentials chapter 1

itt module ca course question papers

italian chicken de soup recipe

it s a shareable life a practical guide on sharing

itil v3 service transition study guide

[isuzu d max service gearbox](#)

[isuzu kb series service repair manual](#)

itil v3 2015 study guide

[isuzu npr alternator wiring diagram](#)

[iveco truck service manual](#)

Manual Perkins 6 Cilindros :

[review vf superman le règne de savage dc planet - Jul 14 2023](#)

web mar 9 2017 comics vf parleonidas publié le9 mars 2017 partager après les action comicsdegrant morrison les superman l homme de demainde geoff johns les superman unchained et d autres urban décide publier le crossover entre ces différentes séries le règne de savage qui amorcera la fin de la période dc you

[règne de savage le par peter j tomasi greg pak gene - Mar 10 2023](#)

web l homme d acier en réchappera t il contre l un des adversaires les plus anciens de l univers dc contient superman savage dawn superman annual 3 action comics 48 50 superman 48 50 superman wonder woman 25 27

superman le règne de savage par gene yang bande - Sep 04 2022

web superman récit complet le règne de savage identité de superman a été dévoilée ou monde entier et ses pouvoirs semblent s affaiblir de façon drastique avec une poignée de justiciers wonder

superman ra gne de savage le pdf pdf devy ortax - Mar 30 2022

web introduction superman ra gne de savage le pdf pdf space is the place john szwed 2020 04 30 considered by many to be a founder of afrofuturism sun ra aka herman blount was a composer keyboardist bandleader philosopher entrepreneur poet and self proclaimed extraterrestrial from saturn

superman le règne de savage collectif comics cultura - Nov 06 2022

web superman le règne de savage par collectif aux éditions urban comics superman a vu son identité dévoilée au monde entier et ses pouvoirs diminuer de façon drastique avec une poignée de justiciers dont wonder woman en tête il p mes réservations choisissez un magasin bonjour identifiez vous

superman ra gne de savage le usa fre01 - Jun 01 2022

web 2 superman ra gne de savage le 2020 05 05 quest to rescue him from the pit will require her to outsmart roderick burgess the most evil man in england puzzle her way through the house of mystery and risk the walking nightmare known as the corinthian in a disintegrating kingdom of dreams nancy and plum millbrook press

superman le règne de savage découvrez sur bubble - Jan 08 2023

web avec une poignée de justiciers dont wonder woman en tête il poursuit néanmoins la lutte mais cette fois il se heurte à un ennemi d une puissance infinie l immortel vandal savage qui a rassemblé une armée autour de lui et dont les membres semblent prêts à tout pour satisfaire celui qu ils appellent père

superman ra gne de savage le download only - Dec 27 2021

web 2 superman ra gne de savage le 2021 08 04 she calls false growth mindset and guides people toward adopting a deeper truer growth mindset she also expands the mindset concept beyond the individual applying it to the cultures of groups and organizations with the right mindset you can motivate those you lead teach and love to

superman le règne de savage excalibur comics - Aug 03 2022

web mais cette fois il se heurte à un ennemi d une puissance infinie l immortel vandal savage qui a rassemblé une armée autour de lui et dont les membres semblent prêts à tout pour satisfaire celui qu ils appellent père l homme d acier en réchappera t il contre l un des adversaires les plus anciens de l univers dc

superman le règne de savage fernando pasarin babelio - Oct 05 2022

web mar 3 2017 la conclusion de superman approche on le sait si l on suite les séries superman l homme de demain ou superman action comics il a récemment perdu la quasi totalité de ses pouvoirs et donc on assiste de plus en plus à des combats dans lesquels l homme d acier n est plus au meilleur de sa forme

savage song and lyrics by genelle bobby crane spotify - Feb 26 2022

web genelle bobby crane song 2019

superman le règne de savage bd informations cotes - May 12 2023

web mar 3 2017 tout sur la série superman le règne de savage superman a vu son identité dévoilée au monde entier et ses pouvoirs diminuer de façon drastique avec une poignée de justiciers dont wonder woman en tête il poursuit néanmoins la lutte

superman ra gne de savage le help environment harvard edu - Jan 28 2022

web with ease as perspicacity of this superman ra gne de savage le can be taken as capably as picked to act variety s who s who in show business mike kaplan 1989 lsd my problem child albert hofmann 2017 09 27 this is the story of lsd told by a concerned yet hopeful father organic chemist albert hofmann ph d he traces lsd s path from a

superman ra gne de savage le full pdf - Apr 30 2022

web superman ra gne de savage le superman ra gne de savage le 2 downloaded from klantenhandboek dutchgiraffe com on 2021 10 14 by guest whom dussel studied with in argentina before his exile to mexico in the late 1970s drawing heavily from the ethical philosophy of emmanuel levinas dussel examines the dominating and liberating

superman ra gne de savage le pdf - Jul 02 2022

web superman ra gne de savage le pdf superman ra gne de savage le 2 downloaded from analytics test makestories io on by guest works in both german and english and then proceeds to comment on the texts with the help of additional brief selections paper edition available 1 55753 157 9 24 95 annotation copyrighted by book news inc

superman le règne de savage matrana - Feb 09 2023

web superman le règne de savage ou la suite des nouvelles aventures de l homme d acier réalisée par les scénaristes greg pak planet hulk peter tomasi batman et robin et gene luen yang superman l homme de demain ainsi qu une multitude d illustreurs dont aaron kuder superman action comics ardian syaf batman superman

superman le règne de savage bedetheque - Jun 13 2023

web mar 18 2017 superman a vu son identité dévoilée au monde entier et ses pouvoirs diminuer de façon drastique avec une poignée de justiciers dont wonder woman en tête il poursuit néanmoins la lutte mais cette fois il se heurte à un ennemi d une puissance infinie l immortel vandal savage qui a rassemblé une armée autour de lui et dont les

superman le règne de savage senscritique - Apr 11 2023

web mar 3 2017 résumé superman a vu son identité dévoilée au monde entier et ses pouvoirs diminuer de façon drastique avec une poignée après le lancement de l'extension senscritique sur navigateur on tire un 1er bilan

superman le règne de savage urban comics - Aug 15 2023

web superman le règne de savage superman a vu son identité dévoilée au monde entier et ses pouvoirs diminuer de façon drastique avec une poignée de justiciers dont wonder woman en tête il poursuit néanmoins la lutte

superman le règne de savage 2017 vive le ciné - Dec 07 2022

web apr 24 2017 savage est l'un des antagonistes les plus intéressants de l'univers dc avec un titre comme celui-ci et la sauce qui montait depuis plusieurs tomes déjà explorer

handbook of nursing diagnosis open library - Aug 03 2022

web apr 15 2020 download nursing diagnosis handbook an evidence based guide to planning care 11th edition pdf free finally in this section of the article you will be

nursing diagnosis handbook revised reprint with 2021 2023 - Apr 30 2022

web dec 10 2021 lynda carpenito's best selling handbook of nursing diagnosis now in an impressive sixteenth edition is the ideal quick reference for nursing diagnosis

cite handbook of nursing diagnosis easybib - Oct 25 2021

nursing diagnosis handbook e book elsevier elibrary - Dec 07 2022

web dec 10 2021 carpenito's best selling handbook of nursing diagnosis now in an impressive sixteenth edition is the ideal quick reference for nursing diagnosis

handbook of nursing diagnosis open library - Sep 04 2022

web handbook of nursing diagnosis 14th edition nursing diagnosis indexcommunication impaired verbal 131 communication impaired 127

nursing diagnosis guide for 2023 complete list tutorial - Jul 14 2023

web from goals to specific interventions handbook of nursing diagnosis focuses on nursing it provides a condensed organized outline of clinical nursing practice designed to

handbook of nursing diagnosis paperback aug 17 2020 - Jul 02 2022

web download now ackley's nursing diagnosis handbook an evidence based guide to planning care 11th edition helps practicing nurses and nursing students select

[handbook of nursing diagnosis lynda juall carpenito google](#) - Sep 23 2021

handbook of nursing diagnosis lynda juall carpenito google - Apr 11 2023

web ackley s nursing diagnosis handbook an evidence based guide to planning care 11th edition helps practicing nurses and nursing students select appropriate nursing

handbook of nursing diagnosis booktopia - Jun 01 2022

web here are handbook of nursing diagnosis citations for 14 popular citation styles including turabian style the american medical association ama style the council of science

handbook of nursing diagnosis 14th edition pdf4pro - Jan 28 2022

nursing diagnosis handbook an evidence based - Feb 26 2022

handbook of nursing diagnosis selected product title - Feb 09 2023

web mar 8 2023 handbook of nursing diagnosis 14th ed by lynda juall carpenito moyet 0 ratings 0 want to read 0 currently reading 0 have read the ideal quick reference this

handbook of nursing diagnosis lynda juall carpenito google - Aug 15 2023

web nov 26 2021 lynda carpenito s best selling handbook of nursing diagnosis now in an impressive sixteenth edition is the ideal quick reference for nursing diagnosis

handbook of nursing diagnosis lynda juall carpenito moyet - May 12 2023

web the ideal quick reference this handbook offers practical guidance on nursing diagnoses and associated care sections cover nursing diagnoses health promotion wellness

handbook of nursing diagnosis carpenito lynda - Nov 06 2022

web may 24 2022 this convenient handbook shows how to correlate nursing diagnoses with known information about clients on the basis of assessment findings established medical

nursing diagnosis handbook 12th edition revised - Mar 10 2023

web aug 18 2010 handbook of nursing diagnosis edit provides information on definitions characteristics related factors outcomes and interventions for nursing diagnoses

handbook of nursing diagnosis kindle edition - Jan 08 2023

web aug 17 2020 carpenito s handbook of nursing diagnosis is the ideal quick reference for nursing diagnosis information this handbook offers practical guidance on nursing

2023 nursing diagnosis guide examples list - Oct 05 2022

web over 5 billion handbook of nursing diagnosis 14th edition is written by lynda juall carpenito rn msn crnp and published

by lippincott williams wilkins the digital

handbook of nursing diagnosis 14th edition vitalsource - Mar 30 2022

read download nursing diagnosis handbook pdf pdf - Nov 25 2021

nursing diagnosis handbook an evidence based guide to - Dec 27 2021

ovid handbook of nursing diagnosis wolters kluwer - Jun 13 2023

web the newly revised eleventh edition of this best selling handbook is an easy to carry accessible guide to the latest nanda approved nursing diagnoses section 1 contains

public financial management pad 852 exam past questions - Jun 16 2022

web may 19 2018 download public financial management pad 852 past questions national open university of nigeria lagos get free past questions answers marking scheme projects and reseach materials test course materials from your favourite hosted institutions

exams for public finance economics free online as pdf docsity - Feb 10 2022

web exams for public finance for economics s students looking for exams in public finance download now thousands of exams in public finance on docsity

multiple choice questions and answers on public finance read - Nov 21 2022

web multiple choice question exam papers in the subjects of business multiple choice questions 50 of its marks and long answer questions 50 of its marks 100 important multiple choice questions on current affairs with answers a national institute of public finance and policy b national institute of bank

exams public finance and public policy economics mit opencourseware - Jul 30 2023

web exams the table below contains exams from the 2009 version of the course as supplemental study material this section provides the midterm exam for the course with solutions exams and solutions from the 2009 version of the course are also provided as supplemental study material

doc final exam mef122 public finance academia edu - Oct 01 2023

web 2019 questions on public finance final exam see full pdf download pdf zcas university master of business administration finance mef122 public finance final examination friday 6th december 2019 16 30 19 30 hrs time allowed three hours instructions 1 section a question one in section a

public finance solved question papers nov 2018 dibugarh university - Feb 22 2023

web mar 28 2021 1 public finance deals with income expenditure and borrowings of the government institutions 2 the finance ministry possesses the expert knowledge in finance matters 3 every tax is an additional burden on the tax payer people 4 public expenditure is more important than private expenditure

[kasneb public finance and taxation past papers and answers](#) - Mar 14 2022

web apr 25 2022 public finance and taxation may 2019 past question paper and answers public finance and taxation november 2018 past question paper and answers public finance and taxation may 2018 past question paper and answers public finance and taxation november 2017 past question paper and answers

[public finance field exam department of economics](#) - Aug 31 2023

web graduate office public finance field exam august 2021 directions answer both questions in whatever order you prefer the exam is open book but you may not consult anyone in composing your answers tax reform

public finance online practice test mcqmate - Sep 19 2022

web practice test on public finance instructions select test length i e small medium large 1 point for each question no points will be given for skipped questions after submission results will be shown instantly with correct choices if you have any query regarding to a question refer to discussion page of respective question

[public finance mcqs public economics multiple choice questions](#) - Mar 26 2023

web multiple choice questions scope of public finance includes a public revenue b public debt c public expenditure d all of these public authorities include a central government b state government c local government d all of these

final exam public finance fall answers pdf free download - May 16 2022

web transcription 1 final exam public finance fall 2004 answers 365final2004 tex 1 multiple choice correct answer indicated by 1 positive economics a does not depend on market interactions b only looks at the best parts of the economy c examines how the economy actually works as opposed to how it should work

[public finance 130 plays quizizz](#) - Oct 21 2022

web public finance quiz for 12th grade students find other quizzes for business and more on quizizz for free

public finance mcqs multiple choice questions and answers - Aug 19 2022

web mar 29 2021 1 public finance notes 2 public finance question papers dibugarh university 3 public finance solved question papers dibugarh university 4 public finance important questions for upcoming exam 29 expenditure of the union government is classified as a revenue expenditure b capital expenditure

public finance free mcq practice test with solutions ca cpt - Jul 18 2022

web the test public finance questions and answers have been prepared according to the ca cpt exam syllabus the test public finance mcqs are made for ca cpt 2023 exam find important definitions questions notes meanings examples exercises mcqs

and online tests for test public finance below

[public finance question paper 2020 public finance pdf prof](#) - May 28 2023

web the paper will include questions origin and development of public finance meaning public finance and federal finance strategic public finance cipfa september 2020 exam paper tough questions for national and local government policymakers

final exam with answer key public finance docsity - Apr 14 2022

web download final exam with answer key public finance econ 344 and more public finance exams in pdf only on docsity econ 344 public finance spring 2005 final exam name the duration of the exam is 1 hour 20 minutes the exam consists of 6 problems and it is worth 100 points

question and answer for june 2018 public sector in financial - Apr 26 2023

web public sector financial management programme examinations diploma level pfm 1 public sector accounting monday 11 june 2018 total marks 100 time allowed three 3 hours instructions to candidates 1 you have fifteen 15 minutes reading time use it

[answers final exam in public finance fall 2018 3 hour closed book exam](#) - Dec 23 2022

web final exam in public finance fall 2018 3 hour closed book exam by jakob egholt søgaard part 1 effective marginal tax rates consider individuals facing the budget constraint $1 - t_x x - z - t_l b = 1$ where x is consumption z is labor earnings e b is a public transfer t_x is a tax rate on consumption and t_l is a lump sum tax the public

public finance questions and answers pdf answers for 2023 exams - Jun 28 2023

web 8991 how to export a file as a pdf pdf format comes with many advantages and makes it easy to share with others too this is why this article talks about the different ways by which you can questions answered net article how to export a file as a pdf get free answers to your personal finance questions today

94 questions with answers in public finance science topic - Jan 24 2023

web sep 19 2023 dariusz prokopowicz asked a question related to public finance how should a real pro social pro family and pro development socio economic policy be conducted question 5 answers may 17 2023