

Holden Cruze Workshop Manual

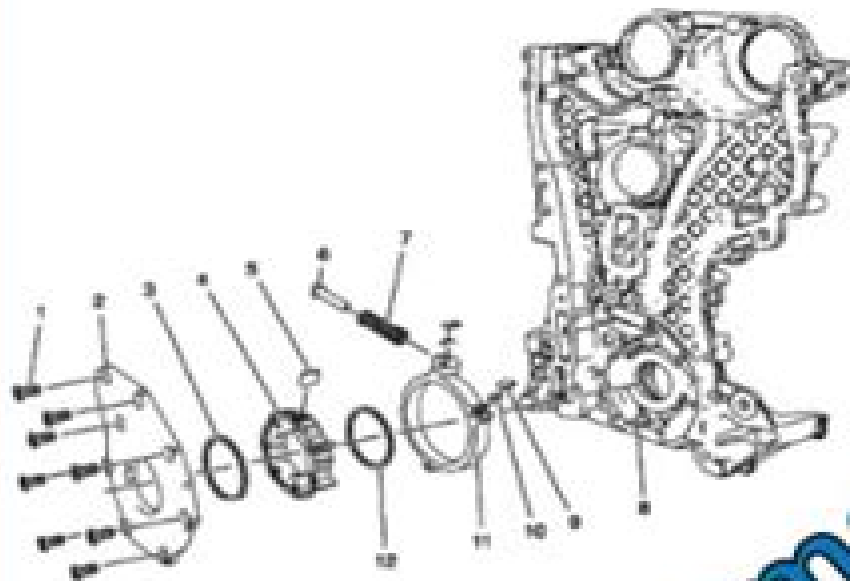

Fig. 2: Engine Front Cover And Oil Pump Assembly. Courtesy of GENERAL MOTORS COMPANY

Callout	Component Name
1	Oil Pump Housing
2	Oil Pump Vanes
3	Oil Pump Vanes Ring
4	Oil Pump Vanes Bush
5	Oil Pump Vanes
6	Oil Pump Slide Spring Pin
7	Oil Pump Slide Spring
8	Oil Pump Slide Pivot Pin
9	Oil Pump Slide Seal
10	Oil Pump Slide Seal Spring
11	Oil Pump Slide
12	Oil Pump Vanes Ring

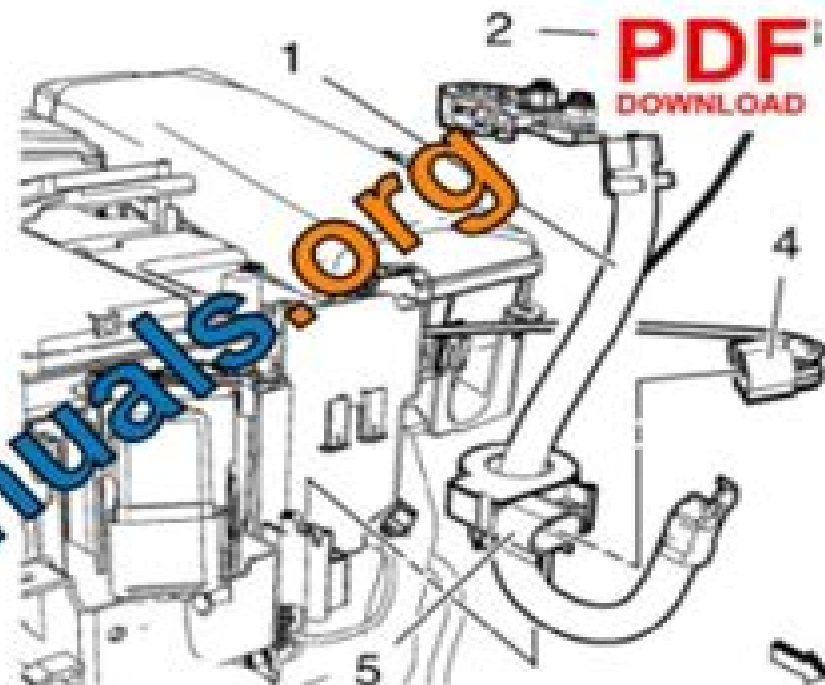

Fig. 24: Wiring Harness Current Sensor Plug. Courtesy of GENERAL MOTORS COMPANY

2. Install the battery negative cable (1).
3. Install the ground cable (2).

CAUTION: Refer to Fastener Caution.

4. Install the battery ground cable to the battery negative cable nut (2) and tighten to 9 N·m.
5. Install the current sensor (3) at the battery tray.
6. Connect the wiring harness current sensor plug (4).

PDF
DOWNLOAD

workshopmanuals.org

Jh Cruze Diesel Workshop Manual

SJ Ball



Jh Cruze Diesel Workshop Manual:

Jh Cruze Diesel Workshop Manual Book Review: Unveiling the Magic of Language

In a digital era where connections and knowledge reign supreme, the enchanting power of language has become more apparent than ever. Its ability to stir emotions, provoke thought, and instigate transformation is really remarkable. This extraordinary book, aptly titled "**Jh Cruze Diesel Workshop Manual**," published by a highly acclaimed author, immerses readers in a captivating exploration of the significance of language and its profound effect on our existence. Throughout this critique, we shall delve into the book's central themes, evaluate its unique writing style, and assess its overall influence on its readership.

https://www.splashdogs.com/About/Resources/Download_PDFS/Hha%20Practice%20Test%20Questions.pdf

Table of Contents Jh Cruze Diesel Workshop Manual

1. Understanding the eBook Jh Cruze Diesel Workshop Manual
 - The Rise of Digital Reading Jh Cruze Diesel Workshop Manual
 - Advantages of eBooks Over Traditional Books
2. Identifying Jh Cruze Diesel Workshop Manual
 - Exploring Different Genres
 - Considering Fiction vs. Non-Fiction
 - Determining Your Reading Goals
3. Choosing the Right eBook Platform
 - Popular eBook Platforms
 - Features to Look for in an Jh Cruze Diesel Workshop Manual
 - User-Friendly Interface
4. Exploring eBook Recommendations from Jh Cruze Diesel Workshop Manual
 - Personalized Recommendations
 - Jh Cruze Diesel Workshop Manual User Reviews and Ratings
 - Jh Cruze Diesel Workshop Manual and Bestseller Lists

5. Accessing Jh Cruze Diesel Workshop Manual Free and Paid eBooks
 - Jh Cruze Diesel Workshop Manual Public Domain eBooks
 - Jh Cruze Diesel Workshop Manual eBook Subscription Services
 - Jh Cruze Diesel Workshop Manual Budget-Friendly Options
6. Navigating Jh Cruze Diesel Workshop Manual eBook Formats
 - ePub, PDF, MOBI, and More
 - Jh Cruze Diesel Workshop Manual Compatibility with Devices
 - Jh Cruze Diesel Workshop Manual Enhanced eBook Features
7. Enhancing Your Reading Experience
 - Adjustable Fonts and Text Sizes of Jh Cruze Diesel Workshop Manual
 - Highlighting and Note-Taking Jh Cruze Diesel Workshop Manual
 - Interactive Elements Jh Cruze Diesel Workshop Manual
8. Staying Engaged with Jh Cruze Diesel Workshop Manual
 - Joining Online Reading Communities
 - Participating in Virtual Book Clubs
 - Following Authors and Publishers Jh Cruze Diesel Workshop Manual
9. Balancing eBooks and Physical Books Jh Cruze Diesel Workshop Manual
 - Benefits of a Digital Library
 - Creating a Diverse Reading Collection Jh Cruze Diesel Workshop Manual
10. Overcoming Reading Challenges
 - Dealing with Digital Eye Strain
 - Minimizing Distractions
 - Managing Screen Time
11. Cultivating a Reading Routine Jh Cruze Diesel Workshop Manual
 - Setting Reading Goals Jh Cruze Diesel Workshop Manual
 - Carving Out Dedicated Reading Time
12. Sourcing Reliable Information of Jh Cruze Diesel Workshop Manual
 - Fact-Checking eBook Content of Jh Cruze Diesel Workshop Manual
 - Distinguishing Credible Sources
13. Promoting Lifelong Learning

- Utilizing eBooks for Skill Development
 - Exploring Educational eBooks
14. Embracing eBook Trends
- Integration of Multimedia Elements
 - Interactive and Gamified eBooks

Jh Cruze Diesel Workshop Manual Introduction

Free PDF Books and Manuals for Download: Unlocking Knowledge at Your Fingertips In today's fast-paced digital age, obtaining valuable knowledge has become easier than ever. Thanks to the internet, a vast array of books and manuals are now available for free download in PDF format. Whether you are a student, professional, or simply an avid reader, this treasure trove of downloadable resources offers a wealth of information, conveniently accessible anytime, anywhere. The advent of online libraries and platforms dedicated to sharing knowledge has revolutionized the way we consume information. No longer confined to physical libraries or bookstores, readers can now access an extensive collection of digital books and manuals with just a few clicks. These resources, available in PDF, Microsoft Word, and PowerPoint formats, cater to a wide range of interests, including literature, technology, science, history, and much more. One notable platform where you can explore and download free Jh Cruze Diesel Workshop Manual PDF books and manuals is the internet's largest free library. Hosted online, this catalog compiles a vast assortment of documents, making it a veritable goldmine of knowledge. With its easy-to-use website interface and customizable PDF generator, this platform offers a user-friendly experience, allowing individuals to effortlessly navigate and access the information they seek. The availability of free PDF books and manuals on this platform demonstrates its commitment to democratizing education and empowering individuals with the tools needed to succeed in their chosen fields. It allows anyone, regardless of their background or financial limitations, to expand their horizons and gain insights from experts in various disciplines. One of the most significant advantages of downloading PDF books and manuals lies in their portability. Unlike physical copies, digital books can be stored and carried on a single device, such as a tablet or smartphone, saving valuable space and weight. This convenience makes it possible for readers to have their entire library at their fingertips, whether they are commuting, traveling, or simply enjoying a lazy afternoon at home. Additionally, digital files are easily searchable, enabling readers to locate specific information within seconds. With a few keystrokes, users can search for keywords, topics, or phrases, making research and finding relevant information a breeze. This efficiency saves time and effort, streamlining the learning process and allowing individuals to focus on extracting the information they need. Furthermore, the availability of free PDF books and manuals fosters a culture of continuous learning. By removing financial barriers, more people can access educational resources and pursue lifelong learning, contributing to

personal growth and professional development. This democratization of knowledge promotes intellectual curiosity and empowers individuals to become lifelong learners, promoting progress and innovation in various fields. It is worth noting that while accessing free Jh Cruze Diesel Workshop Manual PDF books and manuals is convenient and cost-effective, it is vital to respect copyright laws and intellectual property rights. Platforms offering free downloads often operate within legal boundaries, ensuring that the materials they provide are either in the public domain or authorized for distribution. By adhering to copyright laws, users can enjoy the benefits of free access to knowledge while supporting the authors and publishers who make these resources available. In conclusion, the availability of Jh Cruze Diesel Workshop Manual free PDF books and manuals for download has revolutionized the way we access and consume knowledge. With just a few clicks, individuals can explore a vast collection of resources across different disciplines, all free of charge. This accessibility empowers individuals to become lifelong learners, contributing to personal growth, professional development, and the advancement of society as a whole. So why not unlock a world of knowledge today? Start exploring the vast sea of free PDF books and manuals waiting to be discovered right at your fingertips.

FAQs About Jh Cruze Diesel Workshop Manual Books

1. Where can I buy Jh Cruze Diesel Workshop Manual books? Bookstores: Physical bookstores like Barnes & Noble, Waterstones, and independent local stores. Online Retailers: Amazon, Book Depository, and various online bookstores offer a wide range of books in physical and digital formats.
2. What are the different book formats available? Hardcover: Sturdy and durable, usually more expensive. Paperback: Cheaper, lighter, and more portable than hardcovers. E-books: Digital books available for e-readers like Kindle or software like Apple Books, Kindle, and Google Play Books.
3. How do I choose a Jh Cruze Diesel Workshop Manual book to read? Genres: Consider the genre you enjoy (fiction, non-fiction, mystery, sci-fi, etc.). Recommendations: Ask friends, join book clubs, or explore online reviews and recommendations. Author: If you like a particular author, you might enjoy more of their work.
4. How do I take care of Jh Cruze Diesel Workshop Manual books? Storage: Keep them away from direct sunlight and in a dry environment. Handling: Avoid folding pages, use bookmarks, and handle them with clean hands. Cleaning: Gently dust the covers and pages occasionally.
5. Can I borrow books without buying them? Public Libraries: Local libraries offer a wide range of books for borrowing. Book Swaps: Community book exchanges or online platforms where people exchange books.

6. How can I track my reading progress or manage my book collection? Book Tracking Apps: Goodreads, LibraryThing, and Book Catalogue are popular apps for tracking your reading progress and managing book collections. Spreadsheets: You can create your own spreadsheet to track books read, ratings, and other details.
7. What are Jh Cruze Diesel Workshop Manual audiobooks, and where can I find them? Audiobooks: Audio recordings of books, perfect for listening while commuting or multitasking. Platforms: Audible, LibriVox, and Google Play Books offer a wide selection of audiobooks.
8. How do I support authors or the book industry? Buy Books: Purchase books from authors or independent bookstores. Reviews: Leave reviews on platforms like Goodreads or Amazon. Promotion: Share your favorite books on social media or recommend them to friends.
9. Are there book clubs or reading communities I can join? Local Clubs: Check for local book clubs in libraries or community centers. Online Communities: Platforms like Goodreads have virtual book clubs and discussion groups.
10. Can I read Jh Cruze Diesel Workshop Manual books for free? Public Domain Books: Many classic books are available for free as they're in the public domain. Free E-books: Some websites offer free e-books legally, like Project Gutenberg or Open Library.

Find Jh Cruze Diesel Workshop Manual :

hha practice test questions

hexcel composites repair manual

higher gcse maths michael white

high school economics study guide questions

heroes wikipedia episode guide

hesi study guide 3 edition

high school nature scavenger hunt

hewlett packard m1204a manual

high scope routine picture cards

hershey chocolate bar cake recipe

hewlett packard photosmart 318 manual

hid entryprox 4045 manual

high school chemistry lab manual nyc

highway capacity manual hcm 2010

hibbeler statics and mechanics of materials 2014

Jh Cruze Diesel Workshop Manual :

manga player n 11 du 01 09 1996 compiler captain kid my - Jun 17 2023

web jan 9 1996 manga player n 11 du 01 09 1996 compiler capt manga player n 11 du 01 09 1996 compiler captain kid my goddess gunsmith cats 3x3 eyes couverture avant be couvertu market place dedicated to sell and buy european comics manga us comics merchandising erotic and adult manga

komik player komiku - Mar 02 2022

web jun 10 2020 baca komik player bahasa indonesia di komiku up to date soal manga manhua dan manhwa gabung ke komunitas komiku facebook instagram bookmark 01 09 2020 chapter 13 26 08 2020 chapter 12 09 08 2020 chapter 11

manga player no 13 du 01 11 1996 compiler captain pdf full - Sep 08 2022

web manga player no 13 du 01 11 1996 compiler captain pdf this is likewise one of the factors by obtaining the soft documents of this manga player no 13 du 01 11 1996 compiler captain pdf by online you might not require more mature to spend to go to the ebook instigation as skillfully as search for them in some cases you likewise do not discover

player chapter 111 mangatx - Apr 03 2022

web drug eating genius mage september 30 2023 i log in alone october 27 2023 spare me great lord june 16 2022 player chapter 111 through posting a best comment i somehow became the main character of a webtoon

manga player no 13 du 01 11 1996 compiler captain pdf free - Jan 12 2023

web download manga player no 13 du 01 11 1996 compiler captain pdf or read manga player no 13 du 01 11 1996 compiler captain pdf on the most popular online pdf lab only register an account to download manga player no 13 du 01 11 1996 compiler captain pdf online pdf related to manga player no 13 du 01 11 1996 compiler

manga player no 13 du 01 11 1996 compiler captain pdf ma - May 04 2022

web manga player no 13 du 01 11 1996 compiler captain downloaded from ma swischoolwear co uk by guest banks jayce infinite dendrogram manga volume 6 yen press llc ray might be on his way to defeating the gous maiz gang but there s never another crisis far away or the promise of gladitorial combat remember just because

manga player no 13 du 01 11 1996 compiler captain kid my - Dec 31 2021

web manga player no 13 du 01 11 1996 compiler captain kid my goddess gunsmith cats 3x3 eyes street fighter le manga et la video terasawa le pere de cobra by collectif terra formars blu ray rinko kikuchi rila list of slam dunk episodes pricing jw player yugipedia golden mangas ler mangas online em portugus honzuki no gekokujou

manga player no 13 du 01 11 1996 compiler captain pdf free - Feb 13 2023

web manga player no 13 du 01 11 1996 compiler captain pdf free download books manga player no 13 du 01 11 1996 compiler captain pdf books this is the book you are looking for from the many other titles of manga player no 13 du 01 11 1996 compiler captain pdf books here is also available other sources of this manual metcaluser guide

manga player no 13 du 01 11 1996 compiler captain pdf copy - Oct 09 2022

web manga player no 13 du 01 11 1996 compiler captain pdf upload mita s murray 1 8 downloaded from voto.uneal.edu.br on august 18 2023 by mita s murray manga player no 13 du 01 11 1996 compiler captain pdf manga player no 13 du 01 11 1996 compiler captain pdf this is likewise one of the factors by obtaining the soft

player manga top manhwa - Nov 10 2022

web apr 17 2021 during a late night there was a bizarre murdering case in an alley of a small town a few youngsters met a psycho murderer on their way home after a night shift after fighting they found out that the psycho murderer was invulnerable at that decisive moment an angel appeared and killed the evil however who was the ordinary looking

manga player no 13 du 01 11 1996 compiler captain pdf pdf - Dec 11 2022

web jan 11 1996 manga player no 13 du 01 11 1996 compiler captain pdf 1 1 downloaded from agrolinux8.agrositio.com on january 23 2023 by guest manga player no 13 du 01 11 1996 compiler captain pdf getting the books manga player no 13 du 01 11 1996 compiler captain pdf now is not type of challenging means

manga player no 13 du 01 11 1996 compiler captain pdf full - Apr 15 2023

web reki kawahara 2015 03 24 there s no way to beat this game the only difference is when and where you die one month has passed since akihiko kayaba s deadly game began and the body count continues to rise two thousand players are already dead kirito and asuna are two very different people but they both desire to fight alone

manga player no 13 du 01 11 1996 compiler captain kid my - Jul 18 2023

web jan 11 1996 manga player no 13 du 01 11 1996 compiler captain kid my goddess gunsmith cats 3x3 eyes street fighter le manga et la video terasawa le pere de cobra by collectif yugipedia mes animes shonen prfrs 12th manga taisho awards nominate 13 titles news anime boku no hero academia 3rd season my hero academia 3 spring

manga player no 13 du 01 11 1996 compiler captain brandon mull - Feb 01 2022

web jan 11 1996 as this manga player no 13 du 01 11 1996 compiler captain it ends stirring visceral one of the favored books manga player no 13 du 01 11 1996 compiler captain collections that we have this is why you remain in the best website to see the incredible book to have rock art in west papua karina arifin 2004

manga player no 13 du 01 11 1996 compiler captain pdf - Oct 21 2023

web more or less what you need currently this manga player no 13 du 01 11 1996 compiler captain as one of the most

effective sellers here will agreed be accompanied by the best options to review manga player no 13 du 01 11 1996 compiler captain 2021 01 13 chapman gemma manga cultures and the female gaze routledge cÓmo se

player chapter 1 top manhua - Aug 07 2022

web reading player manga at top manhua during a late night there was a bizarre murdering case in an alley of a small town a few youngsters met a psycho murderer on their way home after a 11 13 2023 idoling 05 14 2023 divine emperor 04 26 2021 the dragon prince s bride 11 14 2023 home

access free manga player no 13 du 01 11 1996 compiler captain - Jul 06 2022

web jul 20 2023 compiler captain pdf for free the chess player s chronicle nov 19 2020 journal of the university of durban westville may 26 2021 ebony jul 16 2020 ebony is the flagship magazine of johnson publishing founded in 1945 by john h johnson it still maintains the highest global circulation of any african american focused magazine the

[manga player no 13 du 01 11 1996 compiler captain pdf](#) - May 16 2023

web yet set within the lyrical pages of manga player no 13 du 01 11 1996 compiler captain a charming function of literary splendor that pulses with organic feelings lies an wonderful trip waiting to be embarked upon

manga player no 13 du 01 11 1996 compiler captain kid my - Jun 05 2022

web sep 28 2023 manga player no 13 du 01 11 1996 compiler captain kid my goddess gunsmith cats 3x3 eyes street fighter le manga et la video terasawa le pere de cobra by collectif nanatsu no taizai next generation les 4 cavaliers de l apocalypse read manga online for free online manga reader skaffa any player

manga player no 13 du 01 11 1996 compiler captain pdf - Aug 19 2023

web jan 11 1996 manga player no 13 du 01 11 1996 compiler captain essentials of language documentation jost gippert 2006 01 01 language documentation is a rapidly emerging new field in linguistics which is concerned with the methods tools and theoretical underpinnings for compiling a representative and lasting multipurpose record of a

manga player no 13 du 01 11 1996 compiler captain free pdf - Nov 29 2021

web is the book you are looking for from the many other titlesof manga player no 13 du 01 11 1996 compiler captain pdf books here is alsoavailable other sources of this manual metcaluser guide

[manga player no 13 du 01 11 1996 compiler captain book](#) - Mar 14 2023

web jan 11 1996 manga player no 13 du 01 11 1996 compiler captain best anime of all time 35 series for newbies and veterans paste magazine here are the criterion collection films streaming on max the streamable thursday dec 22 tom cruise is back in the danger zone for top channel guide magazine peggy ovire biography

[manga player no 13 du 01 11 1996 compiler captain pdf mail](#) - Sep 20 2023

web livres de france manga player no 13 du 01 11 1996 compiler captain downloaded from mail thekingiscoming com by

guest townsend annabel histoire de la librairie française yen press llc is she the game s last boss though she doesn t play many mmos maple has either a natural talent or impossibly good luck because by pouring every last

gesprache hilfreich fuhren band 2 psychosoziale p pdf gian - Jul 02 2022

web 2 character profiles describe different symptom clusters that include the waif mother the hermit mother the queen mother and the witch children of borderlines are at risk for

gespräche hilfreich führen band 1 praxis der beratung und - Jan 08 2023

web april 18th 2020 *gespräche hilfreich führen band 2 psychosoziale problemlagen und psychische störungen in personenzentrierter beratung und gesprächspsychotherapie der*

sprachförderung oder sprachtherapie logopädische praxis - Jan 28 2022

web für kinder mit sprachstörungen ist logopädie das heilmittel der wahl eine allgemeine sprachförderung kann ihnen nicht helfen in der regel wird die therapie als

grammatik mitsprache fördern band 2 brigg verlag - Apr 30 2022

web mitsprache fördern band 2 inhaltsverzeichnis leseprobe fragen zum titel band 2 lesekompetenz und schreibkompetenz von staatsinstitut für schulqualität und

gesprache hilfreich fuhren band 2 psychosoziale p - Mar 30 2022

web it is your unquestionably own era to accomplishment reviewing habit among guides you could enjoy now is *gesprache hilfreich fuhren band 2 psychosoziale p* below can

gesprache hilfreich fuhren band 2 psychosoziale p pdf pdf - Sep 16 2023

web *gesprache hilfreich fuhren band 2 psychosoziale p pdf* pages 2 20 *gesprache hilfreich fuhren band 2 psychosoziale p pdf* upload donald c williamson 2 20

pdf *gesprache hilfreich fuhren band 2 psychosoziale p* - Feb 09 2023

web der vorliegende achte band der reihe leadership und angewandte psychologie beleuchtet insbesondere den bedeutenden aspekt der digitalisierung in der vuca welt der unter

gesprache hilfreich fuhren band 2 psychosoziale p copy - Dec 27 2021

web *gesprache hilfreich fuhren band 2 psychosoziale p* 2 10 downloaded from uniport edu ng on may 15 2023 by guest of the changing nature of desire explores how

sprachstörungen bei behinderungen unterstützte kommunikation - Jun 01 2022

web die sprachtherapie bei kindern mit behinderungen hat das vorderste ziel die vermittlung basaler sprachrelevanter fähigkeiten um den spracherwerb zu unterstützen und die

gesprache hilfreich fuhren band 2 psychosoziale p courtenay - Aug 03 2022

web you have remained in right site to begin getting this info acquire the *gesprache hilfreich fuhren band 2 psychosoziale p* connect that we find the money for here and check out

gesprache hilfreich fuhren band 2 psychosoziale p pdf - Oct 05 2022

web *gesprache hilfreich fuhren band 2 psychosoziale p* is available in our digital library an online access to it is set as public so you can get it instantly our digital library spans in

gespräche hilfreich führen band 2 psychosoziale problemlagen - Feb 26 2022

web sep 3 2023 soziale probleme band 1 band 2 springer pdf m schmid amp i arendt 2018 es ist ein wunder full text of 45 psychologiebücher de kundenrezensionen gespräche

gespräche hilfreich führen band 2 psychosoziale problemlagen - Oct 17 2023

web ländliche lebenswelten fallstudien zur landjugend *gespräche hilfreich führen band 2 psychosoziale referat im fach* padagogik methodisches vehen in der digital resources

dialogische sprachförderung bei menschen mit geistiger - Nov 25 2021

web dialogische sprachförderung bei menschen mit geistiger behinderung aus materialistischer sicht sonderpädagogik in forschung und praxis seibel thomas amazon de bücher

kommunikationsförderung für personen ohne lautsprache - Sep 04 2022

web die kommunikationsförderung ermöglicht mehrere wertvolle erfahrungen u a die erfahrung selbst etwas bewirken zu können deshalb zählen auch technische hilfen zur

gesprache hilfreich fuhren band 2 psychosoziale p copy - May 12 2023

web der band 2 der praxisreihe pferdegestützte psychotherapie gibt einen einblick in den einsatz und die wirkung von pferden in der psychotherapeutischen arbeit mit kindern

gesprache hilfreich fuhren band 2 psychosoziale p pdf donn - Mar 10 2023

web jun 27 2023 *gesprache hilfreich fuhren band 2 psychosoziale p pdf* is available in our book collection an online access to it is set as public so you can get it instantly our

gesprache hilfreich fuhren band 2 psychosoziale p pdf - Aug 15 2023

web jun 25 2023 *gesprache hilfreich fuhren band 2 psychosoziale p 2 10* downloaded from uniport edu ng on june 25 2023 by guest theory focusing on the rationale for a

gesprache hilfreich fuhren band 2 psychosoziale p - Nov 06 2022

web present *gesprache hilfreich fuhren band 2 psychosoziale p* and numerous book collections from fictions to scientific research in any way along with them is this

gesprache hilfreich fuhren band 2 psychosoziale p pdf serge - Apr 11 2023

web jun 29 2023 2 with rich clinical data including many case histories to guide the reader based on decades of research from across the globe antoon a leenaars takes the

gespräche hilfreich führen band 2 psychosoziale problemlagen - Dec 07 2022

web aug 21 2023 [gespräche hilfreich führen band 2 psychosoziale problemlagen und psychische störungen in personenzentrierter beratung und may 24th 2020](#)

gesprache hilfreich fuhren band 2 psychosoziale p pdf - Jul 14 2023

web may 21 2023 [gesprache hilfreich fuhren band 2 psychosoziale p 2 9 downloaded from uniport edu ng on may 21 2023](#) by guest counselling provides a definitive source of

gesprache hilfreich fuhren band 2 psychosoziale p pdf - Jun 13 2023

web [gesprache hilfreich fuhren band 2 psychosoziale p 5 5 und tätigkeitsfeldern abzudecken band 2 umfasst 43 kapitel zu praktischen ansätzen von der prävention](#)

shop christian bible studies books bibles lifeway - Jul 25 2022

web an expository book by book study of scripture bible studies for life relatable biblical discipleship rooted in everyday life lifeway is a christian resource since 1891 buy your family and church bible studies christian books bibles christian gifts

[christian bible studies bible study lessons lifeway](#) - Aug 06 2023

web dig deeper into your kids and youth ministries with discipleship and small studies geared specifically for them lifeway offers a variety of christian bible studies lessons for small group women s ministry and sunday school browse our selection of bible study lessons

experiencing god knowing and doing the will of god revised lifeway - Jan 31 2023

web to lifeway press one lifeway plaza nashville tn 37234 0175 isbn 978 1 4158 5838 7 item 005084536 this book is the resource for course cg 0119 in the ministry category of the christian growth study plan dewey decimal classification 231 subject heading god will cover art mike wimmer is one of the nation s leading illustrators

masterlife student edition lifeway s3 amazonaws com - Jul 05 2023

web the christian growth study plan 222 the authors avery t willis jr the author and developer of masterlife is the executive director of the international orality network editor for lifeway christian resources she and her husband louis live in garland texas and have two grown children

the 5 step formula for sunday school growth scene7 - Jun 04 2023

web permission is granted to photocopy the five step formula for sunday school growth a downloadable version is available online at lifeway com sskickoff this book is a resource in the ministry category of the christian growth study plan course cg 1116 printed in the united states of america leadership adult publishing lifeway church

what helps christians grow an exploratory study springer - Mar 21 2022

web apr 1 2019 factor and reliability analyses distinguished between two indicators of christian growth depth of discipleship and strength of vocation and four distinctive pathways to growth growth through group activity growth through christian experience growth through church worship and growth through public engagement

discipleship god s life changing work pullouts lifeway - Aug 26 2022

web dec 7 2014 knowledge of biblical truth knowing and applying daily what i learn br doing in a way these three elements form a discipleship equation for br my new life in christ br being knowing doing growth in christlikeness br to be like christ i must grow in my understanding and application br

ministry grid digital curriculum - Jun 23 2022

web using ministry grid s simple churchwide online platform digital curriculum makes it easier than ever to design personalized discipleship experiences curate customize and create content based on your church s needs distribute relevant resources to leaders includes bible study content and training all in one place with simple sharing

christian growth study plan lifeway pdf db csda - May 23 2022

web study segments to complete between 7 weeks of group sessionsenriching interactive teaching videos approximately 30 minutes per session available for purchase or rent

the life and ministry of paul scene7 - Dec 30 2022

web this book is the text for course cg 0420 in the subject area bible study in the christian growth study plan 800 458 2772 order online at lifeway com or visit the lifeway christian store serving you printed in the united states of america leadership and adult publishing lifeway church resources one lifeway plaza

digital bible studies lifeway - Oct 28 2022

web lifeway s ongoing studies offer a great selection of digital resources to teach and participate in classes virtually or in person explore digital options hyfi bible studies for life explore the bible the gospel project

christian growth study plan celebrates 100th anniversary - Apr 02 2023

web but that s not the case for lifeway christian resources christian growth study plan begun in 1902 under the influence of b w spillman the first field secretary for lifeway cgsp marks its 100th anniversary this year a testimony to the

spiritual growth bible study bible study on growth lifeway - Sep 07 2023

web lifeway com offers bible studies for spiritual growth for all age groups shop bible study lessons on spiritual discipline and warfare from lifeway

spiritual growth assessment process lifeway christian - Oct 08 2023

web the annual spiritual growth plan worksheet helps you formulate an intentional plan for growth use the recommended

actions for spiritual growth guide to discover suggestions for actions to include in your plan as you discuss your plan with an accountability partner you may discover additional actions that more effectively meet your needs

great expectations planting seeds for sunday school growth - Sep 26 2022

web available for free download at that site including teaching plans powerpoint presentations a webinar and an audio version of the book isbn 978 1 4158 6704 4 item 005189412 this book is the text for course ls 0034 in the subject area sunday school in the christian growth study plan dewey decimal classification 268

christian growth study plan lifeway app piphany com - Feb 17 2022

web kindly say the christian growth study plan lifeway is universally compatible with any devices to read 20 20 bible study book christine caine 2023 03 11 christine caine is passionate about seeing every woman equipped to live her life on mission for jesus in this 7 session study you ll develop a new

in the christian growth s yumpu - Apr 21 2022

web understanding today s adults lifeway en english deutsch français español português italiano român nederlands latina dansk svenska norsk magyar bahasa indonesia türkçe suomi latvian lithuanian česk

great expectations planting seeds for sunday school growth - Nov 28 2022

web available for free download at that site including teaching plans powerpoint presentations a webinar and an audio version of the book isbn 978 1 4158 6704 4 item 005189412 this book is a resource for credit in the christian growth study plan for information please visit lifeway com cgsp dewey decimal classification 268

lifeway - Mar 01 2023

web lifeway cgsp english

take a look at the study plan bible studies for life - May 03 2023

web aug 30 2021 it is our mandate to study within each of those each areas each year ensuring that your congregation is growing and maturing in their faith the discipleship pathway is the bedrock of how bible studies for life engages with scripture this fall we have two studies no doubt six things we can know for sure and walking in