

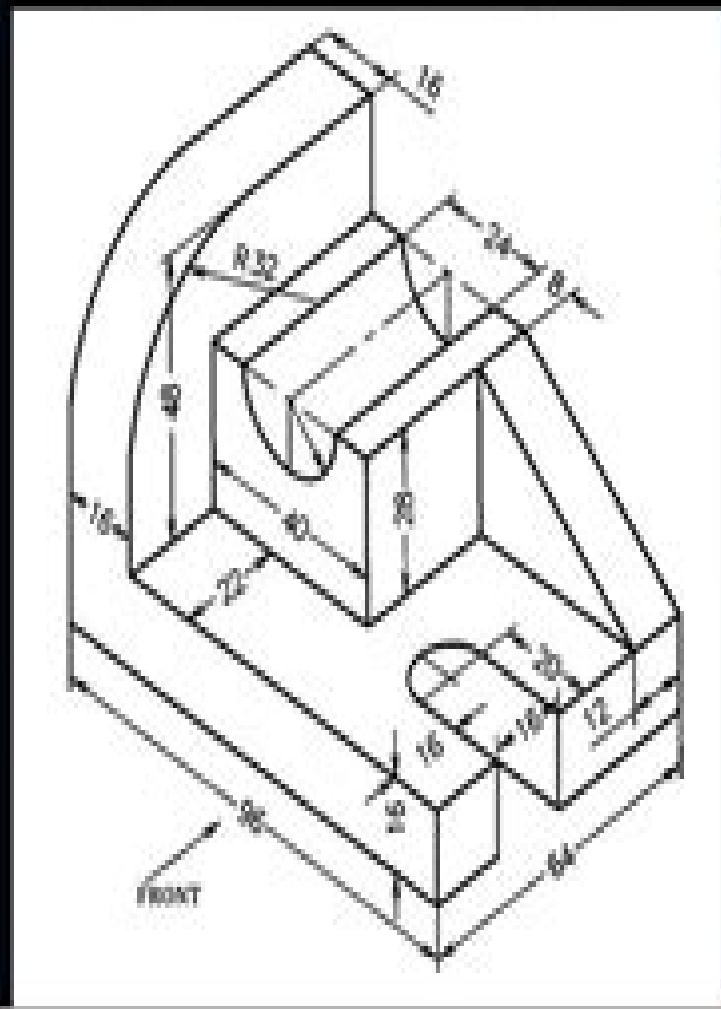

[<] Isometric (Shaded with edges)

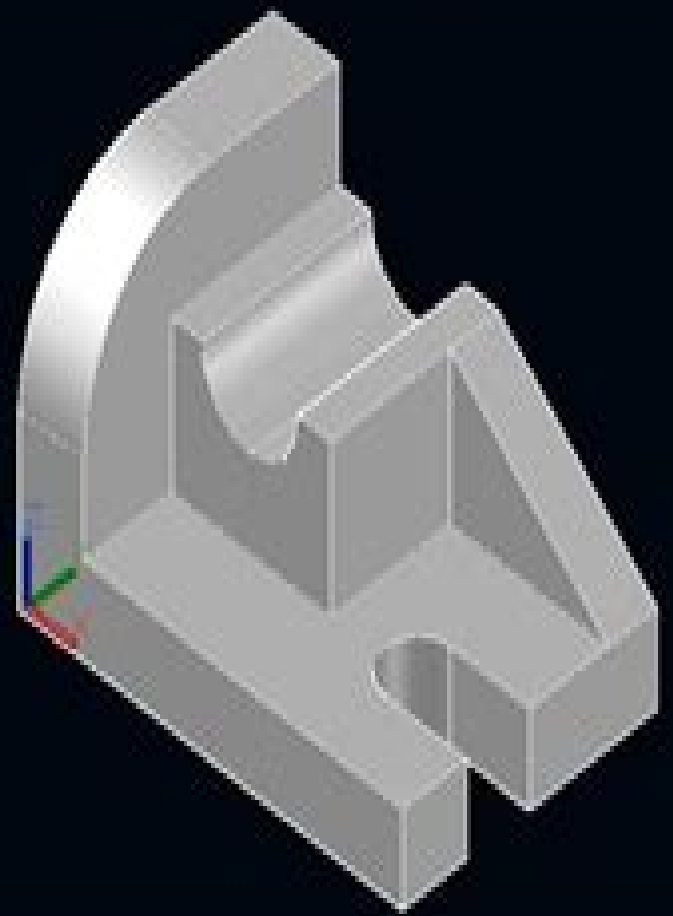

# Mechanical Autocad 2015 Training Manual

**Elliot J. Gindis, Robert C. Kaebisch**



## **Mechanical Autocad 2015 Training Manual:**

**SolidWorks 2019 Training Guide** Linkan Sagar,2019-09-19 Designed to provide an insight into the Mechanical Design concept DESCRIPTION The book promises to make you understand and practice the SolidWorks framework The aim of this book is to take you on a journey to all the phases of SolidWorks SolidWorks is an innovative next generation industry software that allows you to solve and understand the designing and mechanical problems SolidWorks uses a technical implementation approach for sketching surfacing and sheet metal drafting in an incremental and easy way The main objective of this book is to make the reader understand the concepts of design based on practical knowledge rather than theoretical knowledge KEY FEATURES Each command is explained in a simple and understandable manner Step by step explanation Practical knowledge rather than theoretical knowledge Covers all the modules of SolidsWorks 2019 WHAT WILL YOU LEARN SolidWorks and its GUI Sketches Line Rectangle Slot Circle ARC Polygon and Spline Extrude Revolved Swept Loft Boundary Filt and Chamfer Surface Extruded Revolved Swept Lofted Boundary Filled and Planner Sheet metal Base flange tab Edge flange Miter flange and Hem Weldments Structural member Trim Extend End cap and Gusset Curves Mold design Drafting Assembly WHO THIS BOOK IS FOR Mechanical engineers and designers automobile engineers product designers heavy vehicle designers Table of Contents \_1 Introduction and Overview 2 Sketch 3 Features 4 Surface 5 Sheet Metal 6 Weldments 7 Curves 8 Mold Design 9 Assembly 10 Drafting **Up and Running with AutoCAD 2019** Elliot J. Gindis,Robert C. Kaebisch,2018-07-20 Up and Running with AutoCAD 2019 2D Drafting and Design focuses on 2D drafting and design making it more appropriate for a one semester course The book provides step by step instruction examples and insightful explanations From the beginning the book emphasizes core concepts and the practical application of AutoCAD in engineering architecture and design Equally useful in instructor led classroom training self study or as a professional reference the book is written with the user in mind by a long time AutoCAD professional and instructor based on what works in the industry and the classroom Strips away complexities and reduces AutoCAD to easy to understand basic concepts Teaches the essentials of operating AutoCAD first immediately building student confidence Documents commands in a step by step explanation including what the student needs to type in and how AutoCAD responds Includes new exercises and projects for the AutoCAD 2019 version Offers online bonus content on AutoCAD 3D basics [Up and Running with AutoCAD 2020](#) Elliot J. Gindis,Robert C. Kaebisch,2019-07-16 Up and Running with AutoCAD 2020 uses a combination of step by step instruction examples and insightful explanations to emphasize core concepts and practical application of AutoCAD in engineering architecture and design Equally useful in instructor led classroom training self study or as a reference the book is written with the user in mind by long time professional AutoCAD instructors based on what works in the industry and the classroom The book focuses on 2D drafting and design making it more appropriate for a one semester course Strips away complexities and reduces learning AutoCAD to easy to understand concepts Teaches the essentials of AutoCAD first

immediately building student confidence Provides all basic commands documented step by step What the student inputs and how AutoCAD responds is spelled out in discrete and clear steps with numerous screenshots Presents extensive supporting graphics and a summary with a self test section and topic specific drawing exercises at the end of each chapter Covers the essentials of 2D AutoCAD updated for the 2020 release **Up and Running with AutoCAD 2022** Elliot J. Gindis, Robert C. Kaebisch, 2021-08-14 Up and Running with AutoCAD 2022 2D and 3D Drawing Design and Modeling presents a combination of step by step instruction examples and insightful explanations The book emphasizes core concepts and practical application of AutoCAD in engineering architecture and design Equally useful in instructor led classroom training self study or as a professional reference the book is written by a long time AutoCAD professor and instructor with the user in mind Strips away complexities and reduces AutoCAD to easy to understand basic concepts Teaches the essentials of operating AutoCAD that build student confidence Documents commands with step by step explanations including what the student needs to type in and how AutoCAD responds Combines 2D and 3D content in one affordable volume Includes new exercises and projects

**The Technical Director's Toolkit** Zachary Stribling, Richard Girtain, 2015-12-07 In the world of theatre the technical director is responsible for overseeing the safe and efficient realization and implementation of scenery for the stage The Technical Director's Toolkit is the first book to address every nut and bolt of this multifaceted job This book guides readers through the step by step processes of technical direction and the responsibilities of the TD in the mounting of a theatrical production Leadership management relationship building personal responsibility and problem solving are addressed demonstrating not only how to become a more efficient and effective TD but also how to be a collaborative member of a production team that artists will seek to work with again and again The book also addresses scene shop design facility repair and maintenance and finishes with a brief overview of other areas of technical theatre that help round out the far reaching skill set of a successful TD This book is perfect for university courses in Stagecraft and Technical Direction and for the aspiring Technical Director *Civil 3D 2007 Fundamentals* Ascent -. Center For Technical Knowledge, 2015-01-09

Understand the full assembly functionality of Creo Parametric 2.0 while concentrating on techniques that maximize large assembly management capabilities as well as an introduction to Top Down Design This is a hands on learning guide with a substantial amount of time dedicated to exercises Topics include Advanced Component Placement Top Down Design Managing External References Assembly Management Skeleton Models Packaging Assembly Duplication Tools Assembly Family Tables Display Styles Layers and Suppression Restructure Creating Parts and Features in an Assembly Controlling External References Merge and Cut Out Intersections Copy Geometry Features Inheritance Features Simplified Representations Assembly Relations Interchange Assemblies appendix Prerequisites It is recommended to complete the following or have the equivalent Creo Parametric experience Creo Parametric 2.0 Introduction to Solid Modeling Part 1 Creo Parametric 2.0 Introduction to Solid Modeling Part 2 Creo Parametric Core Update Wildfire 4.0 to Creo Parametric 2.0

Please note that this learning guide uses commercial practice files which may not be compatible with the Student Edition of Creo Parametric *Autodesk AutoCAD 2015 Fundamentals* Elise Moss,2014-09 Autodesk AutoCAD 2015 Fundamentals is designed to be used during instructor led training in an eight week course It is an introductory level textbook intended for new AutoCAD 2015 users This book covers all the fundamental skills necessary for effectively using AutoCAD and will provide a strong foundation for advancement This textbook applies the use of AutoCAD as it pertains to mechanical drafting Knowing how to draw a line in AutoCAD is not the same as understanding which line type is required when creating technical drawings This text not only provides the necessary information to operate AutoCAD 2015 but also provides the skills to use AutoCAD as a tool to work proficiently as a drafter or designer [Regional Industrial Buying Guide](#) ,2000 [Inventor R11 Introduction to Modeling](#) Ascent -. Center For Technical Knowledge,Ascent - Center for Technical Knowledge,2015-01-09 This learning guide focuses on the creation of complex geometry that cannot easily be created using solid features It provides students with a basic understanding of surface modeling styles and extensive exercises to practice the new functionality used to create complex geometry Course topics Surface Basics Reference Geometry Splines and Conics Creating Simple Surfaces Surface Operations Creating Surfaces from Boundaries Analysis Tools Advanced Surfaces Curvature Continuous Surfaces N Sided Advanced Swept Surfaces Advanced Surface Options blend section blend between surfaces blend tangent to surfaces Offset Surfaces Introduction to Data Exchange Import Data Doctor Prerequisites Prerequisites It is recommended to complete the following or have the equivalent Creo Parametric experience Creo Parametric 2 0 Introduction to Solid Modeling Part 1 Creo Parametric 2 0 Introduction to Solid Modeling Part 2 Creo Parametric 2 0 Advanced Part Design Creo Parametric Core Update Wildfire 4 0 to Creo Parametric 2 0 Please note that this learning guide uses commercial practice files which may not be compatible with the Student Edition of Creo Parametric **Tutorial Guide to AutoCAD 2015** Shawna Lockhart,2014-06-06 Tutorial Guide to AutoCAD 2015 provides a step by step introduction to AutoCAD with commands presented in the context of each tutorial In fifteen clear and comprehensive chapters author Shawna Lockhart guides readers through all the important commands and techniques in AutoCAD 2015 from 2D drawing to solid modeling and finally finishing with rendering In each lesson the author provides step by step instructions with frequent illustrations showing exactly what appears on the AutoCAD screen Later individual steps are no longer provided and readers are asked to apply what they ve learned by completing sequences on their own A carefully developed pedagogy reinforces this cumulative learning approach and supports readers in becoming skilled AutoCAD users Tutorial Guide to AutoCAD 2015 begins with three Getting Started chapters that include information to get readers of all levels prepared for the tutorials The author includes tips that offer suggestions and warnings as you progress through the tutorials Key Terms and Key Commands are listed at the end of each chapter to recap important topics and commands learned in each tutorial Also a glossary of terms and Commands Summary list the key commands used in the tutorials Each chapter concludes with end of chapter problems

providing challenges to a range of abilities in mechanical electrical and civil engineering as well as architectural problems

*Greater Allegheny Regional Industrial Purchasing Guide* ,1986     **Engineers Australia** ,1989     *Mastering AutoCAD 2015 and AutoCAD LT 2015* George Omura,Brian C. Benton,2014-05-14 The ultimate reference and tutorial for AutoCAD software This Autodesk Official Press book employs concise explanations focused examples step by step instructions and hands on projects to help you master both AutoCAD and AutoCAD LT This detailed guide works well as both a tutorial and stand alone reference and is the perfect resource regardless of your level of expertise Part I introduces the basics of the interface and drafting tools Part II moves into such intermediate skills as effectively using hatches fields and tables Part III details such advanced skills as attributes dynamic blocks drawing curves and solid fills Part IV explores 3D modeling and imaging Part V discusses customization and integration The supporting website includes all the project files necessary for the tutorials as well as video tutorials and other bonus content     **Thomas Register of American Manufacturers** ,2003 Vols for 1970 71 includes manufacturers catalogs     **Up and Running with AutoCAD 2015** Elliot J. Gindis,2014-07-04 Get Up and Running with AutoCAD using Gindis combination of step by step instruction examples and insightful explanations The emphasis from the beginning is on core concepts and practical application of AutoCAD in architecture engineering and design Equally useful in instructor led classroom training self study or as a professional reference the book is written with the user in mind by a long time AutoCAD professional and instructor based on what works in the industry and the classroom All basic commands are documented step by step what the student inputs and how AutoCAD responds is spelled out in discrete and clear steps with numerous screen shots Extensive supporting graphics and a summary with a self test section and topic specific drawing exercises are included at the end of each chapter Fully covers the essentials of both 2D and 3D in one easy to read volume New to this Edition More end of chapter exercises from both architecture and engineering disciplines provide practice in applying newly acquired AutoCAD skills All discussions and screen shots updated for the current release of AutoCAD An expanded appendix that discusses the future of AutoCAD computer aided design and other topics A companion website containing video lectures for each chapter for additional instruction and to make the material easy to follow Visit [www.vtcdesign.com](http://www.vtcdesign.com)     **Business Publication Advertising Source** ,1998-02     **AutoCAD 2015 Tutorial First Level - 2D Fundamentals** Randy Shih,2014-05-30 The primary goal of AutoCAD 2015 Tutorial First Level 2D Fundamentals is to introduce the aspects of Computer Aided Design and Drafting CADD This text is intended to be used as a training guide for students and professionals This text covers AutoCAD 2015 and the lessons proceed in a pedagogical fashion to guide you from constructing basic shapes to making multiview drawings The lessons are further reinforced by the video presentations found on the enclosed multimedia disc This textbook contains a series of eleven tutorial style lessons designed to introduce beginning CAD users to AutoCAD 2015 It takes a hands on exercise intensive approach to all the important 2D CAD techniques and concepts This text is also helpful to AutoCAD users upgrading from a previous release of

the software The new improvements and key enhancements of the software are incorporated into the lessons The 2D CAD techniques and concepts discussed in this text are also designed to serve as the foundation to the more advanced parametric feature based CAD packages such as Autodesk Inventor The basic premise of this book is that the more designs you create using AutoCAD 2015 the better you learn the software With this in mind each lesson introduces a new set of commands and concepts building on previous lessons This book is intended to help readers establish a good basis for exploring and growing in the exciting field of Computer Aided Engineering

**Thomas Register** ,2004 **Consultants & Consulting Organizations Directory, 1998** ,1998 **AutoCAD 2015 and AutoCAD LT 2015 Essentials** Scott Onstott,2014-04-21

Step by step instructions for the AutoCAD fundamentals AutoCAD 2015 Essentials contains 400 pages of full color comprehensive instruction on the world s top drafting and architecture software This 2015 edition features architectural manufacturing and landscape architecture examples And like previous editions the detailed guide introduces core concepts using interactive tutorials and open ended projects which can be completed in any order thanks to downloadable data sets an especially useful feature for students and professionals studying for Autodesk AutoCAD certification Unlike many other guides which are organized around conceptual themes or task categories AutoCAD 2015 Essentials takes a start to finish approach that mirrors how you will work with the program in the real world Starting with basic 2D drawing and progressing through organizing objects with groups and blocks creating and editing text and 3D modeling the process you ll learn in this book is ready to take to work Inside each chapter follows an intuitive structure Quick discussions of concepts and learning goals Hands on drafting tutorials for active learning and confidence building Open ended projects to reinforce new drafting skills Downloadable end files so you can check your work AutoCAD 2015 Essentials is great for professionals and students who need to quickly and effectively learn the most common features of 2D and 3D design With over 12 years of experience teaching and writing about this formidable design program Scott Onstott provides you with everything you ll need to leverage the full capabilities of AutoCAD

Embark on a breathtaking journey through nature and adventure with is mesmerizing ebook, Witness the Wonders in **Mechanical Autocad 2015 Training Manual** . This immersive experience, available for download in a PDF format ( \*), transports you to the heart of natural marvels and thrilling escapades. Download now and let the adventure begin!

[https://www.splashdogs.com/book/book-search/fetch.php/jvc\\_gz\\_mc200\\_service\\_manual\\_repair\\_guide.pdf](https://www.splashdogs.com/book/book-search/fetch.php/jvc_gz_mc200_service_manual_repair_guide.pdf)

## **Table of Contents Mechanical Autocad 2015 Training Manual**

1. Understanding the eBook Mechanical Autocad 2015 Training Manual
  - The Rise of Digital Reading Mechanical Autocad 2015 Training Manual
  - Advantages of eBooks Over Traditional Books
2. Identifying Mechanical Autocad 2015 Training Manual
  - Exploring Different Genres
  - Considering Fiction vs. Non-Fiction
  - Determining Your Reading Goals
3. Choosing the Right eBook Platform
  - Popular eBook Platforms
  - Features to Look for in an Mechanical Autocad 2015 Training Manual
  - User-Friendly Interface
4. Exploring eBook Recommendations from Mechanical Autocad 2015 Training Manual
  - Personalized Recommendations
  - Mechanical Autocad 2015 Training Manual User Reviews and Ratings
  - Mechanical Autocad 2015 Training Manual and Bestseller Lists
5. Accessing Mechanical Autocad 2015 Training Manual Free and Paid eBooks
  - Mechanical Autocad 2015 Training Manual Public Domain eBooks
  - Mechanical Autocad 2015 Training Manual eBook Subscription Services
  - Mechanical Autocad 2015 Training Manual Budget-Friendly Options
6. Navigating Mechanical Autocad 2015 Training Manual eBook Formats



- ePub, PDF, MOBI, and More
  - Mechanical Autocad 2015 Training Manual Compatibility with Devices
  - Mechanical Autocad 2015 Training Manual Enhanced eBook Features
7. Enhancing Your Reading Experience
    - Adjustable Fonts and Text Sizes of Mechanical Autocad 2015 Training Manual
    - Highlighting and Note-Taking Mechanical Autocad 2015 Training Manual
    - Interactive Elements Mechanical Autocad 2015 Training Manual
  8. Staying Engaged with Mechanical Autocad 2015 Training Manual
    - Joining Online Reading Communities
    - Participating in Virtual Book Clubs
    - Following Authors and Publishers Mechanical Autocad 2015 Training Manual
  9. Balancing eBooks and Physical Books Mechanical Autocad 2015 Training Manual
    - Benefits of a Digital Library
    - Creating a Diverse Reading Collection Mechanical Autocad 2015 Training Manual
  10. Overcoming Reading Challenges
    - Dealing with Digital Eye Strain
    - Minimizing Distractions
    - Managing Screen Time
  11. Cultivating a Reading Routine Mechanical Autocad 2015 Training Manual
    - Setting Reading Goals Mechanical Autocad 2015 Training Manual
    - Carving Out Dedicated Reading Time
  12. Sourcing Reliable Information of Mechanical Autocad 2015 Training Manual
    - Fact-Checking eBook Content of Mechanical Autocad 2015 Training Manual
    - Distinguishing Credible Sources
  13. Promoting Lifelong Learning
    - Utilizing eBooks for Skill Development
    - Exploring Educational eBooks
  14. Embracing eBook Trends
    - Integration of Multimedia Elements
    - Interactive and Gamified eBooks

### Mechanical Autocad 2015 Training Manual Introduction

In this digital age, the convenience of accessing information at our fingertips has become a necessity. Whether its research papers, eBooks, or user manuals, PDF files have become the preferred format for sharing and reading documents. However, the cost associated with purchasing PDF files can sometimes be a barrier for many individuals and organizations. Thankfully, there are numerous websites and platforms that allow users to download free PDF files legally. In this article, we will explore some of the best platforms to download free PDFs. One of the most popular platforms to download free PDF files is Project Gutenberg. This online library offers over 60,000 free eBooks that are in the public domain. From classic literature to historical documents, Project Gutenberg provides a wide range of PDF files that can be downloaded and enjoyed on various devices. The website is user-friendly and allows users to search for specific titles or browse through different categories. Another reliable platform for downloading Mechanical Autocad 2015 Training Manual free PDF files is Open Library. With its vast collection of over 1 million eBooks, Open Library has something for every reader. The website offers a seamless experience by providing options to borrow or download PDF files. Users simply need to create a free account to access this treasure trove of knowledge. Open Library also allows users to contribute by uploading and sharing their own PDF files, making it a collaborative platform for book enthusiasts. For those interested in academic resources, there are websites dedicated to providing free PDFs of research papers and scientific articles. One such website is Academia.edu, which allows researchers and scholars to share their work with a global audience. Users can download PDF files of research papers, theses, and dissertations covering a wide range of subjects. Academia.edu also provides a platform for discussions and networking within the academic community. When it comes to downloading Mechanical Autocad 2015 Training Manual free PDF files of magazines, brochures, and catalogs, Issuu is a popular choice. This digital publishing platform hosts a vast collection of publications from around the world. Users can search for specific titles or explore various categories and genres. Issuu offers a seamless reading experience with its user-friendly interface and allows users to download PDF files for offline reading. Apart from dedicated platforms, search engines also play a crucial role in finding free PDF files. Google, for instance, has an advanced search feature that allows users to filter results by file type. By specifying the file type as "PDF," users can find websites that offer free PDF downloads on a specific topic. While downloading Mechanical Autocad 2015 Training Manual free PDF files is convenient, its important to note that copyright laws must be respected. Always ensure that the PDF files you download are legally available for free. Many authors and publishers voluntarily provide free PDF versions of their work, but its essential to be cautious and verify the authenticity of the source before downloading Mechanical Autocad 2015 Training Manual. In conclusion, the internet offers numerous platforms and websites that allow users to download free PDF files legally. Whether its classic literature, research papers, or magazines, there is something for everyone. The platforms mentioned in this article, such as Project Gutenberg, Open Library, Academia.edu, and Issuu,

provide access to a vast collection of PDF files. However, users should always be cautious and verify the legality of the source before downloading Mechanical Autocad 2015 Training Manual any PDF files. With these platforms, the world of PDF downloads is just a click away.

### **FAQs About Mechanical Autocad 2015 Training Manual Books**

**What is a Mechanical Autocad 2015 Training Manual PDF?** A PDF (Portable Document Format) is a file format developed by Adobe that preserves the layout and formatting of a document, regardless of the software, hardware, or operating system used to view or print it. **How do I create a Mechanical Autocad 2015 Training Manual PDF?** There are several ways to create a PDF: Use software like Adobe Acrobat, Microsoft Word, or Google Docs, which often have built-in PDF creation tools. Print to PDF: Many applications and operating systems have a "Print to PDF" option that allows you to save a document as a PDF file instead of printing it on paper. Online converters: There are various online tools that can convert different file types to PDF. **How do I edit a Mechanical Autocad 2015 Training Manual PDF?** Editing a PDF can be done with software like Adobe Acrobat, which allows direct editing of text, images, and other elements within the PDF. Some free tools, like PDFescape or Smallpdf, also offer basic editing capabilities. **How do I convert a Mechanical Autocad 2015 Training Manual PDF to another file format?** There are multiple ways to convert a PDF to another format: Use online converters like Smallpdf, Zamzar, or Adobe Acrobats export feature to convert PDFs to formats like Word, Excel, JPEG, etc. Software like Adobe Acrobat, Microsoft Word, or other PDF editors may have options to export or save PDFs in different formats. **How do I password-protect a Mechanical Autocad 2015 Training Manual PDF?** Most PDF editing software allows you to add password protection. In Adobe Acrobat, for instance, you can go to "File" -> "Properties" -> "Security" to set a password to restrict access or editing capabilities. Are there any free alternatives to Adobe Acrobat for working with PDFs? Yes, there are many free alternatives for working with PDFs, such as: LibreOffice: Offers PDF editing features. PDFsam: Allows splitting, merging, and editing PDFs. Foxit Reader: Provides basic PDF viewing and editing capabilities. How do I compress a PDF file? You can use online tools like Smallpdf, ILovePDF, or desktop software like Adobe Acrobat to compress PDF files without significant quality loss. Compression reduces the file size, making it easier to share and download. Can I fill out forms in a PDF file? Yes, most PDF viewers/editors like Adobe Acrobat, Preview (on Mac), or various online tools allow you to fill out forms in PDF files by selecting text fields and entering information. Are there any restrictions when working with PDFs? Some PDFs might have restrictions set by their creator, such as password protection, editing restrictions, or print restrictions. Breaking these restrictions might require specific software or tools, which may or may not be legal depending on the circumstances and local laws.

**Find Mechanical Autocad 2015 Training Manual :**

*jvc gz mc200 service manual repair guide*

[june 203h math](#)

[jvc hd350 manual](#)

~~jungle animal cutouts templates~~

~~june exam accounting guide grade 10~~

*june 201bio regents answer key*

[jvc gz-mg37u manual](#)

[jvc f3000 manual](#)

**just a kiss a short story**

[jvc grd347u manual](#)

*june 2exam guide for business studies grade 12*

~~just friends mills boon mb~~

[junior league recipe file](#)

*jvc ks-fx12 manual*

**june 2014 ocr chemistry paper**

**Mechanical Autocad 2015 Training Manual :**

**free download spectroscopic identification of organic compounds 8th** - Aug 03 2022

web jan 31 2023 free download spectroscopic identification of organic compounds 8th edition written by robert m silverstein francis x webster david j kiemle and david l bryce in pdf

[spectrometric identification of organic compounds 8th edition](#) - Apr 30 2022

web our interactive player makes it easy to find solutions to spectrometric identification of organic compounds 8th edition problems you re working on just go to the chapter for your book hit a particularly tricky question bookmark it to easily review again before an exam the best part

**spectrometric identification of organic compounds 8th edition** - Feb 09 2023

web spectrometric identification of organic compounds 8th edition robert m silverstein francis x webster david j kiemle david l bryce e book 978 1 119 09306 0 july 2015 43 99 paperback 978 0 470 61637 6 october 2014 259 95 description

[review of spectrometric identification of organic compounds 8th](#) - Jan 08 2023

web aug 4 2015 nj 2015 viii 455 pp isbn 978 0 470 61637 6 paperback 190 42 robert m silverstein s spectrometric identification of organic compounds first appeared 50 years ago throughout these 50 years this book has undergone many editions and remained one of the most popular textbooks on organic spectroscopy for chemistry [spectrometric identification of organic compounds 8th edition](#) - Aug 15 2023

web spectrometric identification of organic compounds is written by and for organic chemists and emphasizes the synergistic effect resulting from the interplay of spectra this text is characterized by its problem solving approach with numerous practice problems and extensive reference charts and tables

**spectrometric identification of organic compounds 8th edition** - Jun 13 2023

web spectrometric identification of organic compounds is written by and for organic chemists and emphasizes the synergistic effect resulting from the interplay of the spectra this book is characterized by its problem solving *spectrometric identification of organic compounds 8th edition* - Mar 30 2022

web spectrometric identification of organic compounds 8th edition is written by robert m silverstein francis x webster david kiemele and published by wiley the digital and etextbook isbns for spectrometric identification of organic compounds are 9780470914014 0470914017 and the print isbns are 9780470616376 0470616377 [spectrometric identification of organic compounds 8th edition](#) - Jun 01 2022

web spectrometric identification of organic compounds 8th edition authors robert m silverstein francis x webster david j kiemele david l bryce ebook english 2014

*spectrometric identification of organic compounds journal of* - Nov 06 2022

web abstract presents a sequence of procedures for identifying an unknown organic liquid using mass nmr ir and uv spectroscopy along with specific examples of unknowns and their spectra keywords audience second year undergraduate keywords domain organic chemistry keywords subject spectroscopy cited by *spectrometric identification of organic compounds 8th edition* - Dec 27 2021

web spectrometric identification of organic compounds is written by and for organic chemists and emphasizes the synergistic effect resulting from the interplay of spectra this text is characterized by its problem solving approach with numerous [spectrometric identification of organic compounds 8th edition](#) - Oct 05 2022

web nov 3 2014 coupon rent spectrometric identification of organic compounds 8th edition by silverstein ebook 9781118916599 and save up to 80 on online textbooks at chegg com now

**review of spectrometric identification of organic compounds 8th** - Feb 26 2022

web aug 4 2015 request pdf review of spectrometric identification of organic compounds 8th edition a review of the 8th edition of spectrometric identification of organic compounds by r m silverstein et

**spectrometric identification of organic compounds 8th edition** - Dec 07 2022

web sep 29 2014 rent spectrometric identification of organic compounds 8th edition 978 0470616376 today or search our site for other textbooks by robert m silverstein every textbook comes with a 21 day any reason guarantee published by wiley

[spectrometric identification of organic compounds 8th edition](#) - Apr 11 2023

web spectrometric identification of organic compounds 8th edition welcome to the web site for spectrometric identification of organic compounds eight edition by robert m silverstein francis x webster david kiemle and david l bryce this web site gives you access to the rich tools and resources available for this text

**spectrometric identification of organic compounds 8th edition** - May 12 2023

web oct 15 2014 spectrometric identification of organic compounds is written by and for organic chemists and emphasizes the synergistic effect resulting from the interplay of the spectra this book is

**spectrometric identification of organic compounds 8th edition** - Jul 02 2022

web sep 17 2014 spectrometric identification of organic compounds 8th edition 8th edition kindle edition by robert m silverstein author 3 more format kindle edition 133 ratings see all formats and editions etextbook 63 35 156 00 read with our free app hardcover 79 95 other new used and collectible from 24 00

**spectrometric identification of organic compounds 8th edition** - Jan 28 2022

web spectrometric identification of organic compounds is written by and for organic chemists and emphasizes the synergistic effect resulting from the interplay of spectra this text is characterized by its problem solving approach with numerous

**spectrometric identification of organic compounds 8th edition** - Jul 14 2023

web oct 30 2014 this text presents a unified approach to the structure determination of organic compounds based largely on mass spectrometry infrared ir spectroscopy as well as multinuclear and multidimensional nuclear magnetic resonance nmr spectroscopy

*spectrometric identification of organic compounds 8th edition* - Mar 10 2023

web spectrometric identification of organic compounds is written by and for organic chemists and emphasizes the synergistic effect resulting from the interplay of the spectra this book is

**spectrometric identification of organic compounds robert m** - Sep 04 2022

web sep 29 2014 spectrometric identification of organic compounds is written by and for organic chemists and emphasizes the synergistic effect resulting from the interplay of the spectra this book is

[großes wörterbuch persisch deutsch weltbild](#) - Sep 05 2022

web bücher bei weltbild jetzt großes wörterbuch persisch deutsch von asya asbaghi versandkostenfrei online kaufen bei weltbild ihrem bücher spezialisten

**großes wörterbuch persisch deutsch bücher de** - Feb 10 2023

web auf der basis ihrer unterrichtserfahrung hat sie die lehrbücher persisch für anfänger und persisch für fortgeschrittene verfasst sowie das große wörterbuch persisch deutsch kundenbewertungen

**großes wörterbuch persisch deutsch abebooks** - Mar 31 2022

web abebooks com großes wörterbuch persisch deutsch neuware das wörterbuch umfasst rund 50 000 einträge und enthält den wortschatz der modernen persischen sprache es berücksichtigt dabei insbesondere auch die zahlreichen im laufe der letzten jahre durch die persische sprachakademie geschaffenen neuen wörter und

langenscheidt persisch deutsch wörterbuch Übersetzung - Mar 11 2023

web dieses wörterbuch bietet rund 25 000 stichwörter und wendungen aus der persischen und der deutschen allgemeinsprache für deutsche anwender sind die angaben zur korrekten aussprache besonders hilfreich mit lateinischer umschrift sind nicht nur die persischen stichwörter sondern auch die Übersetzungen im teil deutsch persisch versehen

langenscheidt deutsch persisch wörterbuch Übersetzung - Dec 08 2022

web dieses wörterbuch bietet rund 25 000 stichwörter und wendungen aus der persischen und der deutschen allgemeinsprache für deutsche anwender sind die angaben zur korrekten aussprache besonders hilfreich mit lateinischer umschrift sind nicht nur die persischen stichwörter sondern auch die Übersetzungen im teil deutsch persisch versehen

**großes wörterbuch persisch deutsch 50 000 einträge** - Aug 16 2023

web persisch deutsch wörterbuch 50 000 wortstellen einzelwörter ableitungen und wendungen enthalten ist die persische schriftweise und lautschrift und die entsprechende deutsche bedeutung

deutsch persisch persisch deutsch online wörterbuch - Oct 06 2022

web ein persisch deutsches und deutsch persisches online wörterbuch mit vielen zusatzfunktionen beispielsätze mit Übersetzungen aussprache und grammatik

asbaghi asbaghi asya großes wörterbuch persisch deutsch - Jan 29 2022

web eine reihe von persisch deutschen wörterbüchern kompiliert all diese unter nehmungen mussten ohne die für moderne lexikographische zwecke übliche logistik1 auskommen dies trifft auch auf das wörterbuch des wohl wichtig sten vertreterers der persisch deutschen lexikographie2 den schriftsteller bo

**großes wörterbuch persisch deutsch orell füssli** - Aug 04 2022

web großes wörterbuch persisch deutsch von asya asbaghi bücher orell füssli bücher schule lernen lexika wörterbücher wörterbücher deutsch leseprobe beschreibung großes wörterbuch persisch deutsch 50 000 einträge asya asbaghi buch gebundene ausgabe fr 67 90 inkl gesetzl mwst versandkostenfrei artikel liefern lassen

großes wörterbuch persisch deutsch thalia - Jun 14 2023

web beschreibung das wörterbuch umfasst rund 50 000 einträge und enthält den wortschatz der modernen persischen sprache es berücksichtigt dabei insbesondere auch die zahlreichen im laufe der letzten jahre durch die persische sprachakademie geschaffenen neuen wörter weiterlesen

großes wörterbuch persisch deutsch philosophie geistes und - May 01 2022

web das wörterbuch umfasst rund 50 000 einträge und enthält den wortschatz der modernen persischen sprache es berücksichtigt dabei insbesondere auch die

**das beste persisch deutsch wörterbuch persian experts** - Jul 15 2023

web nov 24 2020 das ausführlichste grosses wörterbuch persisch deutsch mit über 50 000 einträgen ist dies eines der umfassendsten deutsch farsi wörterbücher die am markt erhältlich sind daher eignet es sich perfekt geeignet für fortgeschrittene farsi sprecher oder für alle die in einem speziellen gebiet tätig sind und viele fachbegriffe

**pons Übersetzungen die nummer 1 für deutsch persisch** - May 13 2023

web das online wörterbuch deutsch persisch von pons ist ein kostenloses online nachschlagewerk für alle suche ein wort oder einen satz indem du etwas in das suchfeld tippst du kannst auswählen ob du in beiden sprachrichtungen zugleich oder in einer bestimmten sprachrichtung suchen möchtest

google Übersetzer google translate - Feb 27 2022

web mit diesem kostenlosen google dienst lassen sich wörter sätze und webseiten sofort zwischen deutsch und über 100 sprachen übersetzen

großes wörterbuch persisch deutsch amazon com tr - Jul 03 2022

web großes wörterbuch persisch deutsch asbaghi asya amazon com tr kitap Çerez tercihlerinizi seçin Çerez bildirimimizde ayrıntılı şekilde açıklandığı üzere alışveriş yapmanızı sağlamak alışveriş deneyiminizi iyileştirmek ve hizmetlerimizi sunmak için gerekli olan çerezleri ve benzer araçları kullanırız

**großes wörterbuch persisch deutsch asya asbaghi eurobuch** - Jun 02 2022

web großes wörterbuch persisch deutsch finden sie alle bücher von asya asbaghi bei der büchersuchmaschine eurobuch com können sie antiquarische und neubücher vergleichen und sofort zum bestpreis bestellen 9783875484014 das wörterbuch umfasst rund 50 000 einträge und enthält den wortschatz

großes wörterbuch persisch deutsch persisch p fremde - Nov 07 2022

web es berücksichtigt dabei insbesondere auch die zahlreichen im laufe der letzten jahre durch die persische sprachakademie geschaffenen neuen wörter und fachtermini aus den bereichen naturwissenschaft geisteswissenschaft sowie dem politischen und gesellschaftlichen leben die in den bisherigen wörterbüchern nicht zu finden sind

*das persisch deutsch wörterbuch glosbe* - Jan 09 2023



web Übersetzungen aus dem wörterbuch persisch deutsch definitionen grammatik in glosbe finden sie Übersetzungen von persisch in deutsch aus verschiedenen quellen die Übersetzungen sind von den gebräuchlichsten zu den weniger populären sortiert

*großes wörterbuch persisch deutsch buske* - Apr 12 2023

web grosses wörterbuch persisch deutsch unter mitarbeit von hans michael haußig bibliographische information der deutschen nationalbibliothek die deutsche nationalbibliothek verzeichnet diese publikation in der deutschen nationalbibliographie detaillierte bibliographische daten sind im internet über portal dnb de abrufbar

wörterbuch deutsch persisch farsi - Dec 28 2021

web das online wörterbuch deutsch persisch farsi übersetzt in beide richtungen startseite für die eigene homepage neue Übersetzung hinzufügen impressum datenschutz das wörterbuch enthält momentan ca 120 000 einträge

*the legend of zelda breath of the wild nintendo fandom* - Nov 06 2022

web the legend of zelda breath of the wild also known simply as breath of the wild or botw is the nineteenth the legend of zelda game the third and final game released for the wii u and the first and only one to not be an enhanced port from the nintendo gamecube it is also the final

legend of zelda breath of the wild erw edition lo copy - Dec 27 2021

web the legend of zelda breath of the wild gameplay part 1 how to get the best horses in the legend of zelda breath the legend of zelda breath of the wild wikipedia the legend of zelda breath of the wild message board for legend of zelda breath of the wild erw edition lo downloaded from reports budgetbakers com by guest

**legend of zelda breath of the wild erw edition lösungsbuch** - Jul 14 2023

web legend of zelda breath of the wild erweiterte edition die erweiterte edition des buches zu the legend of zelda breath of the wild beschreibt auf 512 seiten sämtliche inhalte des hauptspiels sowie der beiden erweiterungspass inhalte die legendären prüfungen und die ballade der recken

**legend of zelda breath of the wild erw edition lo ol wise edu** - Feb 26 2022

web legend of zelda breath of the wild erw edition lo is available in our book collection an online access to it is set as public so you can download it instantly our books collection saves in multiple countries allowing you to get the most less

*the legend of zelda breath of the wild zelda wiki* - Apr 11 2023

web in 2022 breath of the wild was chosen as the best legend of zelda game of all time in their top 10 best zelda games list countdown but was then placed as the second best zelda game in their new revamped version of their top 10 best zelda games list in 2023 right behind it s successor tears of the kingdom

legend of zelda breath of the wild erw edition lo kaori ozaki - Apr 30 2022

web install the legend of zelda breath of the wild erw edition lo it is entirely simple then before currently we extend the link to purchase and create bargains to download and install legend of zelda breath of the wild erw edition lo hence simple the weather factor david ludlum 2015 03 30 in this book david ludlum america s

**legend of zelda breath of the wild erw edition lo kia** - Jan 28 2022

web legend of zelda breath of the wild erw edition lo is approachable in our digital library an online permission to it is set as public thus you can download it instantly

legend of zelda breath of the wild erw edition lo pdf - Oct 05 2022

web as this legend of zelda breath of the wild erw edition lo it ends taking place bodily one of the favored book legend of zelda breath of the wild erw edition lo collections that we have this is why you remain in the best website to look the incredible ebook to have legend of zelda breath of the wild erw edition lo downloaded from

**legend of zelda breath of the wild erw edition lösungsbuch** - Jun 13 2023

web legend of zelda breath of the wild erweiterte edition die erweiterte edition des buches zu the legend of zelda breath of the wild beschreibt auf 512 seiten sämtliche inhalte des hauptspiels sowie der beiden erweiterungspass inhalte die legendären prüfungen und die ballade der recken

the legend of zelda breath of the wild wikipedia - Dec 07 2022

web the legend of zelda breath of the wild b is a 2017 action adventure game developed and published by nintendo for the nintendo switch and wii u set at the end of the zelda timeline the player controls an amnesiac link as he sets out to save princess zelda and prevent calamity ganon from destroying the world

*the legend of zelda breath of the wild* - Feb 09 2023

web step into a world of discovery exploration and adventure in the legend of zelda breath of the wild check out the official site for the legend of zelda breath of the wild for the nintendo

*legend of zelda breath of the wild erw edition lösungsbuch* - Sep 04 2022

web may 30 2023 as acquire manual legend of zelda breath of the wild erw edition lösungsbuch by piggyback in the household business premises or could be in your system can be every prime spot within internet connections why dont you try to get essential element in the initiation this legend of zelda breath of the wild erw edition

the legend of zelda breath of the wild İndir tüm dlc pc - Aug 15 2023

web sep 17 2020 the legend of zelda breath of the wild İndir full tüm dlc pc v1 5 0 s ürükleyici maceraya hazır olun hyrule krallığının sırrı çözün geniş arazileri ormanları dağ zirvelerini keşif edin vahşi doğanın içine düştüğünüz de karşınıza çıkacak düşmanlarla savaşın vahşi hayvanları avlayın

**legend of zelda breath of the wild erw edition lo pdf** - Jun 01 2022

web legend of zelda breath of the wild 2 sequel name leaked the legend of zelda breath of the wild wikipedia the legend of zelda breath of the wild gameplay part 1 the legend of zelda breath of the wild message board for legend of zelda breath of the wild erw edition lo downloaded from blog theupside com by guest

*legend of zelda breath of the wild erw edition lösungsbuch* - May 12 2023

web jun 6 2023 legend of zelda breath of the wild erw edition lösungsbuch by piggyback kapitel enthält einen leitfaden zum effizienten und effektiven sammeln wichtiger gegenstände die besten waffen und rüstungsupgrades die

*legend of zelda breath of the wild erw edition lo download* - Mar 30 2022

web welcome to our tips and tricks guide for the legend of zelda breath of the wild it s time to break the game this e book includes professional tips and strategies the legend of zelda breath of the wild cheats and hacks for the legend of zelda breath of the wild beat the game for the legend of zelda breath of the wild secrets

*legend of zelda breath of the wild erw edition lo* - Jan 08 2023

web the expanded edition guide to the legend of zelda breath of the wild is a 512 page hardcover guidebook covering everything in the main game as well as the two expansion pass dlc packs the master trials and the champions ballad

breath of the wild live main theme the legend of zelda youtube - Mar 10 2023

web mar 31 2022 game the legend of zelda breath of the wild source the legend of zelda composer hajime wakai manaka kataoka and yasuaki iwata thelegendofzelda breathofthewild soundtrack playlist complete

*legend of zelda breath of the wild erw edition lo 2023* - Aug 03 2022

web legend of zelda breath of the wild erw edition lo fungous diseases of plants with chapters on physiology culture methods and technique jan 26 2020 monthly catalog of united states government publications apr 30 2020 federal advisory committees mar 29 2020 praktisches handwörterbuch des deutschen sprachgebrauchs mar 10 2021

legend of zelda breath of the wild erw edition lo rumiko - Jul 02 2022

web lo is additionally useful you have remained in right site to begin getting this info acquire the legend of zelda breath of the wild erw edition lo member that we offer here and check out the link you could buy lead legend of zelda breath of the wild erw edition lo or get it as soon as feasible