

Land Rover Series IIA 1961-1971 Workshop Manual



Fig. 8-3—Assembly of connecting rod and piston

Cylinder bores and walls, to refit Operation A.196

1. Remove the cooling ring grommets at the crankcase end of cylinder block bores, and the lower cooling rings, with Mueser M24 Compressors, then fit a ring to the upper and lower grommets of each bore.

A small hole is drilled through the block into the middle grommet to the crankside of coolant leakage point.



Fig. 8-10—Checking cylinder bore diameter

2. Press the bores into their respective bores in block and scribe the marks made while the working.
3. Clean each bore in turn in the manner described and tighten the securing bolts to 45 lbf-ft (6.1 mkg) torque. Mount a dial test indicator and check that the outer edge of the cylinder bore is true to .002 to .004 in. (0.076 to 0.127 mm) above the cylinder head seat face. See Fig. A.75. Adjust if necessary by increasing bore and adding a suitable shim washer under the flange. Clamp and re-check bore as described above. Shim washers are available .002 in. (0.051 mm) and .004 in. (0.102 mm) thick.

Pistons and rings, to refit Operation A.198

1. When fitting pistons, the clearance in bore must be checked by an micrometer with the dimensions laid down in the Data Section. In the absence of specially accurate measuring instruments, a long feeler, .004 in. (0.102) mm thick, may be inserted in the lowest part of the bore, then, as illustrated in Fig. A.76, and the piston located across diameter and the gageless gap in line with the centre line of cylinder block. The piston should receive a light fit when the feeler is slid across the bore.
2. Check the piston ring gap in the bore bores, using an oil piston as illustrated in Fig. A.74, to keep the rings square in the bore.



Fig. 8-11—Checking piston ring gap

3. The second and third compression rings are fitted edge, and must be fitted with the side marked "T" uppermost; the top chrome-plated compression and the oil scraper ring face a square friction edge and may be fitted either way. Fit the piston rings and check the clearance in ring grooves. See Data Section.

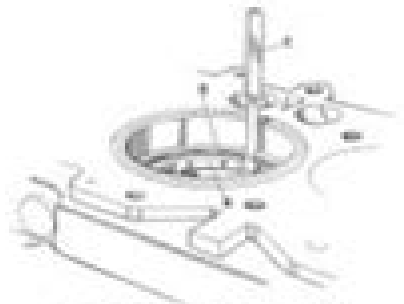

Fig. 8-12—Checking piston ring gap

It will be seen that provision is made for the fitting of two oil scraper rings. The second groove is for service purposes only.

Connecting rod checks Operation A.200

1. Check that the connecting rods and caps have not been fitted, in the following manner.
 2. Select the correct cap for each connecting rod, as dictated by the number stamped near the seat faces. The number also indicates the weights to which it must be fitted.
- Assemble the connecting rods, low dust bearings, with corresponding washers together.

Land Rover Series I Service Repair Workshop Manual

R Barnett



Land Rover Series I Service Repair Workshop Manual:

Land Rover Series 2, 2A and 3 1958-85 Owner's Workshop Manual John Harold Haynes,1995 Land Rover Service and Repair Manual John Harold Haynes,Marcus Daniels,1995 Series II IIA III inc County with 88 109 inch wheelbase Does NOT cover 24V electrical systems or forward control models Petrol 2 1 4 litre 2286cc 4 cyl Does NOT cover 6 cyl or V8 engines *Land Rover Series II, IIA and III Maintenance and Upgrades Manual* Richard Hall,2016-06-30 Based on real life experience and written by expert authors the books in the Maintenance and Upgrades Manual series from Crowood will help owners develop the workshop skills needed for the maintenance and repair of their cars and give guidance on possibilities for improvements and upgrades to performance With step by step instructions and safety information throughout this book is a valuable technical resource for owners of Series II IIA and III Land Rovers The book covers choosing and buying a Series II or III Land Rover maintenance and service procedures detailed guides for repair and maintenance of each of the car s systems including brakes steering and suspension engine clutch and transmission axles hubs and propshafts and electrical systems repairing and preventing corrosion upgrades for reliability comfort performance and off roading rebuilding a Series II or III Land Rover things to know before you take on a project car This practical guide and technical resource for all Series II IIA and III owners and Land Rover enthusiasts is fully illustrated with over 280 colour photographs Land Rover Series I-III Maurice Thurman,2011 A conveniently sized comprehensive troubleshooter for Series I II and III Land Rovers Identifies the most common problems from engine noises to suspension issues and provides quick often innovative roadside repairs to get you moving again Also offers advice on more extensive repairs Covering most civilian models including both petrol and diesel engines this is an essential book for Land Rover drivers Page 4 of cover *Land Rover Discovery Service and Repair Manual* Steve Rendle,Mark Coombs,Robert Jex,2000 Models include Commercial special limited editions Does NOT cover revised range introduced December 1998 Petrol 3 5 litre 3528cc 3 9 litre 3947cc V8 Does NOT cover 2 0 litre Mpi petrol engine Turbo Diesel 2 5 litre 2495cc 4 cyl Tdi *Land Rover Series II, IIA and III* John Harold Haynes,John S. Mead,2012-12 A service and repair manual for the Land Rover series II IIA III **Land Rover 90, 110 and Defender Diesel Service and Repair Manual** Mark Coombs,Steve Rendle,2007 90 110 Defender Diesel including Pick up Hard Soft Top County Station Wagon Also covers most features of 130 Diesel Does NOT cover Land Rover Special Vehicles options conversions Diesel 2 1 4 litre 2286cc 2 5 litre 2495cc normally aspirated Turbo Diesel engines including TD5 engine *Land Rover Freelander Petrol and Diesel Service and Repair Manual* Martynn Randall,R. M. Jex,2007 97 Sept 03 R to 53 Softback Hardback Station Wagon inc special limited editions Does NOT cover new range introduced September 2003 Petrol 1 8 litre 1796cc 4 cyl Does NOT cover 2 5 litre V6 petrol engine Turbo Diesel 2 0 litre 1951cc DOHC 1994cc SOHC **Land Rover Discovery Diesel** Steve Rendle,Mark Coombs,1995 **Land Rover Freelander Service and Repair Manual** Martynn Randall,Robert Jex,2002 Tuning and Modifying the Rover V8 Engine Daniel R Lloyd,Nathan J Lloyd,2019-09-27 This is the ultimate book for any

enthusiast or professional who is tuning or modifying the Rover V8 engine This essential read covers all aspects of tuning this versatile and much loved engine with an emphasis on selecting the correct combination of parts for your vehicle and its intended use Topics cover the short engine cylinder head modifications and aftermarket cylinder heads camshaft and valve train intake and exhaust systems cooling system carburettors and fuel injection distributor and distributor less ignition systems engine management LPG conversions and finally supercharging and turbo charging

Land Rover Discovery Maintenance and Upgrades Manual, Series 1 and 2 Ralph Hosier,2014-10-31 Based on real life experiences and written by expert authors the books in the Maintenance and Upgrades series from Crowood will help owners develop the workshop skills needed for the maintenance and repair of their cars and give guidance on possibilities for improvements and upgrades to performance With step by step instructions and safety information throughout this book is a valuable technical resource for owners of the Land Rover Discovery Series 1 and 2 Illustrated with over 300 photographs the book covers sourcing parts and tools common problems and solutions covering all engine types including Rover V8 and diesel engines service and repair improvements for wheels and tyres and detailed specifications This valuable technical guide for owners of the Land Rover Discovery Series 1 and 2 will be of particular interest to home and professional mechanics and Land Rover enthusiasts specialists and owners clubs Illustrated with over 300 colour photographs

Land Rover Brooklands Books,2008-05 The information in this book has been specially selected for the practical owner who enjoys carrying out basic maintenance and repairs Information is taken from Land Rovers library including workshop manuals SJR900 ENWN LRL0079ENG parts catalogue RTC9947CF Handbook SJR 820 ENHB 90

American Book Publishing Record ,1979

Land Rover Discovery Diesel Owners Workshop Manual Martynn Randall,2012

Proceedings Institution of Mechanical Engineers (Great Britain),1951

Whitaker's Books in Print ,1998

Land Rover Diesel Series Iia and III 1958-85 Service and Repair Manual John Harold Haynes,John S. Mead,1997 Series IIA III inc County with 88 109 inch wheelbase Does NOT cover 24V electrical systems Diesel 2 1 4 litre 2286cc 4 cyl Does NOT cover 2 5 litre

Books in Print Supplement ,1978

Journal Institution of Mechanical Engineers (Great Britain),1951

Unveiling the Energy of Verbal Beauty: An Emotional Sojourn through **Land Rover Series I Service Repair Workshop Manual**

In a world inundated with displays and the cacophony of instantaneous transmission, the profound energy and emotional resonance of verbal beauty often disappear in to obscurity, eclipsed by the continuous assault of sound and distractions. However, located within the lyrical pages of **Land Rover Series I Service Repair Workshop Manual**, a interesting function of fictional beauty that impulses with natural thoughts, lies an memorable journey waiting to be embarked upon. Penned by a virtuoso wordsmith, this mesmerizing opus instructions viewers on an emotional odyssey, gently exposing the latent potential and profound influence embedded within the complex web of language. Within the heart-wrenching expanse with this evocative examination, we can embark upon an introspective exploration of the book is central subjects, dissect its fascinating publishing model, and immerse ourselves in the indelible impression it leaves upon the depths of readers souls.

https://www.splashdogs.com/book/publication/Download_PDFS/Ford%20Fiesta%20Style%202006%20Manual.pdf

Table of Contents Land Rover Series I Service Repair Workshop Manual

1. Understanding the eBook Land Rover Series I Service Repair Workshop Manual
 - The Rise of Digital Reading Land Rover Series I Service Repair Workshop Manual
 - Advantages of eBooks Over Traditional Books
2. Identifying Land Rover Series I Service Repair Workshop Manual
 - Exploring Different Genres
 - Considering Fiction vs. Non-Fiction
 - Determining Your Reading Goals
3. Choosing the Right eBook Platform
 - Popular eBook Platforms
 - Features to Look for in an Land Rover Series I Service Repair Workshop Manual
 - User-Friendly Interface
4. Exploring eBook Recommendations from Land Rover Series I Service Repair Workshop Manual

- Personalized Recommendations
 - Land Rover Series I Service Repair Workshop Manual User Reviews and Ratings
 - Land Rover Series I Service Repair Workshop Manual and Bestseller Lists
5. Accessing Land Rover Series I Service Repair Workshop Manual Free and Paid eBooks
 - Land Rover Series I Service Repair Workshop Manual Public Domain eBooks
 - Land Rover Series I Service Repair Workshop Manual eBook Subscription Services
 - Land Rover Series I Service Repair Workshop Manual Budget-Friendly Options
 6. Navigating Land Rover Series I Service Repair Workshop Manual eBook Formats
 - ePub, PDF, MOBI, and More
 - Land Rover Series I Service Repair Workshop Manual Compatibility with Devices
 - Land Rover Series I Service Repair Workshop Manual Enhanced eBook Features
 7. Enhancing Your Reading Experience
 - Adjustable Fonts and Text Sizes of Land Rover Series I Service Repair Workshop Manual
 - Highlighting and Note-Taking Land Rover Series I Service Repair Workshop Manual
 - Interactive Elements Land Rover Series I Service Repair Workshop Manual
 8. Staying Engaged with Land Rover Series I Service Repair Workshop Manual
 - Joining Online Reading Communities
 - Participating in Virtual Book Clubs
 - Following Authors and Publishers Land Rover Series I Service Repair Workshop Manual
 9. Balancing eBooks and Physical Books Land Rover Series I Service Repair Workshop Manual
 - Benefits of a Digital Library
 - Creating a Diverse Reading Collection Land Rover Series I Service Repair Workshop Manual
 10. Overcoming Reading Challenges
 - Dealing with Digital Eye Strain
 - Minimizing Distractions
 - Managing Screen Time
 11. Cultivating a Reading Routine Land Rover Series I Service Repair Workshop Manual
 - Setting Reading Goals Land Rover Series I Service Repair Workshop Manual
 - Carving Out Dedicated Reading Time
 12. Sourcing Reliable Information of Land Rover Series I Service Repair Workshop Manual

- Fact-Checking eBook Content of Land Rover Series I Service Repair Workshop Manual
 - Distinguishing Credible Sources
13. Promoting Lifelong Learning
- Utilizing eBooks for Skill Development
 - Exploring Educational eBooks
14. Embracing eBook Trends
- Integration of Multimedia Elements
 - Interactive and Gamified eBooks

Land Rover Series I Service Repair Workshop Manual Introduction

Free PDF Books and Manuals for Download: Unlocking Knowledge at Your Fingertips In today's fast-paced digital age, obtaining valuable knowledge has become easier than ever. Thanks to the internet, a vast array of books and manuals are now available for free download in PDF format. Whether you are a student, professional, or simply an avid reader, this treasure trove of downloadable resources offers a wealth of information, conveniently accessible anytime, anywhere. The advent of online libraries and platforms dedicated to sharing knowledge has revolutionized the way we consume information. No longer confined to physical libraries or bookstores, readers can now access an extensive collection of digital books and manuals with just a few clicks. These resources, available in PDF, Microsoft Word, and PowerPoint formats, cater to a wide range of interests, including literature, technology, science, history, and much more. One notable platform where you can explore and download free Land Rover Series I Service Repair Workshop Manual PDF books and manuals is the internet's largest free library. Hosted online, this catalog compiles a vast assortment of documents, making it a veritable goldmine of knowledge. With its easy-to-use website interface and customizable PDF generator, this platform offers a user-friendly experience, allowing individuals to effortlessly navigate and access the information they seek. The availability of free PDF books and manuals on this platform demonstrates its commitment to democratizing education and empowering individuals with the tools needed to succeed in their chosen fields. It allows anyone, regardless of their background or financial limitations, to expand their horizons and gain insights from experts in various disciplines. One of the most significant advantages of downloading PDF books and manuals lies in their portability. Unlike physical copies, digital books can be stored and carried on a single device, such as a tablet or smartphone, saving valuable space and weight. This convenience makes it possible for readers to have their entire library at their fingertips, whether they are commuting, traveling, or simply enjoying a lazy afternoon at home. Additionally, digital files are easily searchable, enabling readers to locate specific information within seconds. With a few keystrokes, users can search for keywords, topics, or phrases, making research and

finding relevant information a breeze. This efficiency saves time and effort, streamlining the learning process and allowing individuals to focus on extracting the information they need. Furthermore, the availability of free PDF books and manuals fosters a culture of continuous learning. By removing financial barriers, more people can access educational resources and pursue lifelong learning, contributing to personal growth and professional development. This democratization of knowledge promotes intellectual curiosity and empowers individuals to become lifelong learners, promoting progress and innovation in various fields. It is worth noting that while accessing free Land Rover Series I Service Repair Workshop Manual PDF books and manuals is convenient and cost-effective, it is vital to respect copyright laws and intellectual property rights. Platforms offering free downloads often operate within legal boundaries, ensuring that the materials they provide are either in the public domain or authorized for distribution. By adhering to copyright laws, users can enjoy the benefits of free access to knowledge while supporting the authors and publishers who make these resources available. In conclusion, the availability of Land Rover Series I Service Repair Workshop Manual free PDF books and manuals for download has revolutionized the way we access and consume knowledge. With just a few clicks, individuals can explore a vast collection of resources across different disciplines, all free of charge. This accessibility empowers individuals to become lifelong learners, contributing to personal growth, professional development, and the advancement of society as a whole. So why not unlock a world of knowledge today? Start exploring the vast sea of free PDF books and manuals waiting to be discovered right at your fingertips.

FAQs About Land Rover Series I Service Repair Workshop Manual Books

What is a Land Rover Series I Service Repair Workshop Manual PDF? A PDF (Portable Document Format) is a file format developed by Adobe that preserves the layout and formatting of a document, regardless of the software, hardware, or operating system used to view or print it. **How do I create a Land Rover Series I Service Repair Workshop Manual PDF?** There are several ways to create a PDF: Use software like Adobe Acrobat, Microsoft Word, or Google Docs, which often have built-in PDF creation tools. Print to PDF: Many applications and operating systems have a "Print to PDF" option that allows you to save a document as a PDF file instead of printing it on paper. Online converters: There are various online tools that can convert different file types to PDF. **How do I edit a Land Rover Series I Service Repair Workshop Manual PDF?** Editing a PDF can be done with software like Adobe Acrobat, which allows direct editing of text, images, and other elements within the PDF. Some free tools, like PDFescape or Smallpdf, also offer basic editing capabilities. **How do I convert a Land Rover Series I Service Repair Workshop Manual PDF to another file format?** There are multiple ways to convert a PDF to another format: Use online converters like Smallpdf, Zamzar, or Adobe Acrobats export feature to

convert PDFs to formats like Word, Excel, JPEG, etc. Software like Adobe Acrobat, Microsoft Word, or other PDF editors may have options to export or save PDFs in different formats. **How do I password-protect a Land Rover Series I Service Repair Workshop Manual PDF?** Most PDF editing software allows you to add password protection. In Adobe Acrobat, for instance, you can go to "File" -> "Properties" -> "Security" to set a password to restrict access or editing capabilities. Are there any free alternatives to Adobe Acrobat for working with PDFs? Yes, there are many free alternatives for working with PDFs, such as: LibreOffice: Offers PDF editing features. PDFsam: Allows splitting, merging, and editing PDFs. Foxit Reader: Provides basic PDF viewing and editing capabilities. How do I compress a PDF file? You can use online tools like Smallpdf, ILovePDF, or desktop software like Adobe Acrobat to compress PDF files without significant quality loss. Compression reduces the file size, making it easier to share and download. Can I fill out forms in a PDF file? Yes, most PDF viewers/editors like Adobe Acrobat, Preview (on Mac), or various online tools allow you to fill out forms in PDF files by selecting text fields and entering information. Are there any restrictions when working with PDFs? Some PDFs might have restrictions set by their creator, such as password protection, editing restrictions, or print restrictions. Breaking these restrictions might require specific software or tools, which may or may not be legal depending on the circumstances and local laws.

Find Land Rover Series I Service Repair Workshop Manual :

[ford fiesta style 2006 manual](#)

ford fiesta haynes manual 2002 to 2008

[ford ef el workshop manual](#)

[ford falcon au service repair manual 1998 2002](#)

[ford expedition 2001 owners manual](#)

ford falcon xb manual

ford expedition recall brake line on 2009

[ford f53 motorhome chassis manual](#)

ford f150 brake repair

ford f 750 wiring diagram

[ford falcon au xr6](#)

ford explorer 2002 to 2005 factory workshop service repair manual

ford falcon ba workshop manual

[ford essex v6 engine manual](#)

ford explorer repair manual torrent

Land Rover Series I Service Repair Workshop Manual :

ulimaji bora wa bamia muungwana blog - Feb 15 2022

web nov 21 2018 namna bora ya kupanda zao la bamia kibiashara zaidi ni kuzingatia kanuni za kilimo bora na chenye tija upandaji ukuaji na hata uvunaji wa bamia ni lazima usimamiwe kwa ukaribu zaidi kwa ajili ya kuleta tija iliyokusudiwa ustawishaji zao hili hustawi katika mita 1000 kutoka usawa wa bahari na hushindwa kuvumilia hali ya baridi

kilimo cha bamia kangeta - May 01 2023

web kilimo cha bamia kilimo cha bamia bamia ni zao la jamii ya mbogamboga linalotambulika kitaalamu kama abelmoschus esculentus okra lenye asili ya afrika ya magharibi kwa sasa zao hili linalimwa katika nchi nyingi hasa sehemu za joto

kilimo bora cha bamia mkulima sua ac tz - Aug 04 2023

web mahitaji ya kiikolojia hali ya hewa na mwinuko bamia ni zao linalopendelea hali ya joto hivyo hustawi katika maeneo yenye hali joto kuanzia nyuzi joto za sentigredi 21 hadi 35 ustawi mzuri zaidi huonekana katika maeneo yenye joto la nyuzi za sentigredi 21 mpaka 30 hali joto zaidi ya nyuzi za sentigredi 42 huweza kusababisha kudondoka kwa maua

utangulizi wa kilimo bora cha korosho tanzania wauzaji - Apr 19 2022

web utangulizi wa kilimo bora cha korosho tanzania lenald minja september 27 2023 17402 views korosho ni mbegu inayokua kwenye mti wa mkorosho pia korosho yenyewe inakua pamoja na tunda linaloitwa bibo na mbegu huonekana nje kati ya mwaka 1560 na 1565 mti huu ulipelekwa hadi goa india na mabaharia wa ureno kutoka hapo ulienea

kilimo bora cha bamia tanzania wauzaji - Jun 02 2023

web muda wa kuandaa shamba la bamia liandaliwe mapema mwezi mmoja kabla ya kupanda ili kuruhusu magugu na mabaki ya mazao kuoza vizuri kwa kilimo cha bamia kwa kutegemea mvua ni vyema maandalizi yaanze mapema kabla ya kuanza kwa mvua za masika inashauriwa kuanza maandalizi mapema mwezi januari

kilimo cha bamia fahamu kuhusu mbegu bora mazingira sahihi - Oct 26 2022

web nov 8 2015 1 baadhi ya maswali yaliyoulizwa na wadau kuhusu kilimo hiki mwenye kufahamu ufanisi wa hiki kilimo atujuze mambo yafuatayo 1 mbegu bora zinapatikana wapi 2 zinachukua muda gani kukomaa 3 masoko yake yako wapi 4 bei ya kuuza inakwendaje asanteni jahlex said habarini wakuu

jinsi ya kulima bamia jifunze kilimo cha bamia la mgongo youtube - Feb 27 2023

web jan 13 2021 jifunze namna unavyoweza kulima bamia likakupa faida bamia ni zao la mboga lakini pia linaweza kua tiba ni kati ya mazao yanayoliwa sanaa na kupendwa sanaa kwasasa hivyo basi kupitia ukurasa

utangulizi wa kilimo cha bamia wauzaji - Aug 24 2022

web kilimo cha bamia kwa tanzania ni kilimo maarufu sana kwasababu bamia ni zao linalolimwa sana nchi za joto na zao la

bamia hutumika kama mboga matumizi ya bamia bamia hupikwa pamoja na nyama samaki au mboga nyingine jinsi ya kupanda bamia

[kilimo cha bamia mkoani unguja youtube](#) - Sep 24 2022

web usisahau kutufuatilia katika mitandao yetu subscribe to our youtube channel bit ly itvtanzaniafacebook bit ly 2keqnl3twitter htt

kilimo bora cha bamia sehemu ya kwanza 01 muungwana blog - Mar 19 2022

web aug 26 2019 kilimo bora cha bamia sehemu ya kwanza 01 muungwana blog 2 8 26 2019 10 30 00 pm bamia ni zao la mbogamboga linalotambulika kitaalamu kama abelmoschus esculentus lenye asili ya ethiopia na afrika ya magharibi kwa sasa zao hili linalimwa katika nchi nyingi hasa sehemu za joto

[kilimo bora cha bamia ocr mabusi h m agricultural](#) - Jul 03 2023

web namna bora ya kupanda zao la bamia kibiashara zaidi ni kuzingatia kanuni za kilimo bora na chenye tija upandaji ukuaji na hata uvunaji wa bamia ni lazima usimamiwe kwa ukaribu zaidi kwa ajili ya kuleta tija iliyokusudiwa ustawishaji zao hili hustawi katika mita 1000 kutoka usawa wa bahari na hushindwa kuvumilia hali ya baridi kali

[kilimo bora cha bamia okra tanzania na kilimo](#) - Mar 31 2023

web apr 19 2017 utangulizi bamia ni moja ya zao la mbogamboga ambayo asili yake ni hapa hapa africa na nchini ethiopia ambapo kwa sasa linalimwa katika nchi nyingine nyingi bamia ni moja kati ya mazao ambayo yanafaida sana ndani ya mwili wa binadamu usaidia kusafisha utumbo mpana

jinsi ya kulima bamia kitaalamu inavyotakiwa ili kupata mazao mengi - Dec 28 2022

web kilimo cha bamia bamia ni zao linalolimwa sana nchi za joto zipo aina nyingi za bamia aina zile za kiasili nazo hutofautiana kulingana na eneo moja na lingine bamia huliwa kama matunda au hupikwa kama mboga pamoja na nyama samaki au mboga nyingine jinsi ya kupanda bamia mambo muhimu ya kuzingatia katika kilimo cha bamia

[kilimo cha bamia kisasa okra shamba darasa kibaha youtube](#) - Jun 21 2022

web 255717274387kangetakilimo co tzk

[kilimo cha bamia muungwana blog](#) - Nov 26 2022

web mar 10 2016 kilimo cha bamia popo 3 10 2016 10 30 00 pm bamia asili ya mboga hii ni afrika ya kati na ya mashariki lakini kwa sasa zao hili limekwisha enea katika sehemu nyingi za kitropiki kama visiwa vya caribbean malaysia na philippines urefu wa mmea huwa kati ya meta moja na mbili

[kilimo cha bamia muongozo wa mafanikio mogriculture tz](#) - Oct 06 2023

web mar 18 2023 kwenye mwongozo huu tutadurusu vipengele muhimu vya kilimo cha bamia nchini tanzania ikijumuisha maandalizi ya shamba jinsi ya kupanda mahitaji ya udongo mahitaji ya mbolea udhibiti wa wadudu na magonjwa na mbinu za

kuvuna

kilimo bora cha bamia kilimo na ufugaji - May 21 2022

web bamia hustawi vizuri katika maeneo 1000 mita kutoka usawa wa bahari kuandaa shamba kama mazao mengine shamba la bamia linatakiwa kusafishwa vizuri na pia unaweza kuweka mbolea ya asili kama vile mboji samadi na mbolea ya kuku upandaji bamia ni moja kati ya mazao rahisi sana kuhudumia kama mtu ukiwa makini

kanuni na teknolojia bora za uzalishaji na usimamizi wa zao la kilimo - Sep 05 2023

web kutoka wizara ya kilimo makao makuu fahmia amiri selemani kutoka chuo cha mafunzo ya kilimo cha mboga matunda na maua horti tengeru hussein issa issaka na athumani almasi mpanda kutoka wizara ya tawala za mikoa na serikali za mitaa tamisemi katika idara ya kilimo ya halmashauri ya

masomo ya kilimo mographiculture tz - Jul 23 2022

web mar 22 2023 jifunze zaidi kuhusu kilimo bora na mazao ya kilimo kupitia blog yetu ya kilimo tunakuletea machapisho bora zaidi kutoka kwa wataalamu wetu wa kilimo

mboga mboga na matunda mographiculture tz - Jan 29 2023

web kilimo cha bamia muongozo wa mafanikio bamia ni zao la mbogamboga linalotambulika kitaalamu kama abelmoschus esculentus lenye asili ya ethiopia read more mazao ya mizizi mboga mboga na matunda jinsi ya kufanya kilimo bora cha karoti karoti ni nini karoti kwa jina la kisayansi inajulikana kama daucus carota

3516c diesel generator sets scene7 - Dec 29 2022

web every cat engine is full load tested to ensure proper engine performance product support offered through global cat dealer network more than 2 200 dealer outlets caterpillar

3516c industrial diesel engines cat caterpillar - Jun 03 2023

web continuous operation at varying load and speed with duration of idle between applied loads typical load factor 40 50 engine performance is corrected to inlet air standard

[manual 3516 cat pdf document](#) - Oct 07 2023

web scan to find and purchase genuine cat parts and related service information language original instructions operation and maintenance manual 3512c and 3516c marine

caterpillar 3516c hd operation and maintenance manual - Mar 20 2022

web for your largest power needs in any environment cat 3516 industrial diesel engines offer the unsurpassed performance and durability your customers need to keep their

3516 land drilling engines and generator sets cat caterpillar - May 22 2022

web cat engine 3516 c parts manual pdf uploaded by reza 0 0 october 2021 pdf bookmark embed download this document

was uploaded by user and they confirmed that they

3516c imo ii commercial propulsion engines cat caterpillar - Jul 24 2022

web mar 4 2021 reflect actual engine 3516c dimensions marine propulsion engine 3045 mhp 3003 bhp 2240 bkw 3194 mhp 3150 bhp 2350 bkw 3432 mhp 3385 bhp

3516 industrial diesel engines cat caterpillar - Dec 17 2021

3516c hd 2237 bkw 3000 bhp land well service engine - Feb 28 2023

web the cat 3516 industrial diesel engine is offered in ratings ranging from 1011 1492 bkw 1355 2000 bhp 1200 1800 rpm these ratings are non certified and are available for

3516 industrial diesel engines cat caterpillar - Sep 06 2023

web check out current offers for the 3516c view more offers the cat 3516c is offered at 1506 bkw 2100 bhp 1750 rpm this engine is available using epa u s flex

3516b generator set electric power - Jun 22 2022

web nov 22 2021 engine identification caterpillar engines are identified with serial numbers with performance specification numbers and with arrangement numbers in some of the

operation and maintenance manual cat publications - Aug 05 2023

web the 3516c propulsion engine is available with a wide range cat data link engine diagnostics general alarm relay programmable parameters system application and

marine propulsion engine scene7 - Apr 20 2022

web get spare parts for caterpillar 3516c easily from our partners inquire the spare part you search for from our partners with a few easy steps and choose the best offer whether you

3516c generator set electric power - Oct 27 2022

web the 3516c propulsion engine is available with a wide range of ratings that meet imo ii regulations without any additional aftertreatment these engines provide efficient

cat mss new - Nov 27 2022

web engine specifications engine model 3516 ta v 16 4 stroke water cooled diesel compression ratio 13 0 1 the generators used on cat packages have been designed

3516c hd offshore generator set scene7 - Sep 25 2022

web if you are looking for a detailed specification sheet of the cat 3516b diesel generator set you can download it from this link this pdf document provides information on the

[cat mss new](#) - Aug 25 2022

web overview cat 3516 engines set the standard in the drilling industry for many years the 3500 has been the preferred choice by drillers due to their high performance durability

[3516b industrial diesel engines cat caterpillar](#) - Nov 15 2021

[caterpillar 3516c specifications technical data 2022 2023](#) - Jan 18 2022

[3516c generator set electric power emc cat com](#) - Apr 01 2023

web aug 16 2017 cat diesel engine designed and optimized for low fuel consumption reliable performance proven in thousands of applications worldwide generator set

diesel generator sets scene7 - Jan 30 2023

web cat product support including dealer service parts and warranty covers the entire cat power system world wide product support cat dealers have over 1 800 dealer branch

cat engine 3516 c parts manual pdf x25d47l36lwp - Feb 16 2022

web for your largest power needs in any environment cat 3516b industrial diesel engines offer the unsurpassed performance and durability your customers need to keep their

cat mss new - May 02 2023

web sep 6 2017 3516c 60 hz 2050 2500 ekw u s epa tier 4 final spec sheet scene7learn about the features and benefits of the cat 3516c diesel generator set

[3516c 60 hz 1650 2500 kw diesel generator cat](#) - Jul 04 2023

web engine specifications engine model 3516c ataac v 16 4 stroke water cooled diesel bore 170 mm 6 69 in stroke std 190 mm 7 48 in stroke hd 215 mm 8 46 in

american inspiration workbook 4 answers pdf uniport edu - Dec 09 2022

web apr 11 2023 american inspiration workbook 4 answers 1 7 downloaded from uniport edu ng on april 11 2023 by guest american inspiration workbook 4 answers right here we have countless book american inspiration workbook 4 answers and collections to check out we additionally offer variant types and furthermore type of the

[american inspiration workbook 4 answers](#) - Oct 07 2022

web american inspiration workbook 4 answers but end up in infectious downloads rather than enjoying a good book with a cup of tea in the afternoon instead they are facing with some malicious bugs inside their desktop computer american inspiration workbook 4 answers is available in our book collection an online

american inspiration workbook 4 answers sexybots - Apr 01 2022

web apr 1 2023 of this american inspiration workbook 4 answers can be taken as skillfully as picked to act an answer to a late book intituled a discourse concerning the inventions of men in the worship of god by william lord bishop of derry robert craghead 1694 demons the answer book lester sumrall 2003 09 01

american inspiration for teens 4 teacher s book - May 14 2023

web american inspiration for teens 4 teacher s book student s book workbook with cd rom authors philip prowse judy garton sprenger publisher macmillan do brasil isbn 8574186678 9788574186672 export citation bibtex endnote refman

american inspiration workbook 4 answers pdf download only - Jun 03 2022

web apr 28 2023 compilations in this website it will very ease you to see guide american inspiration workbook 4 answers pdf as you such as american inspiration workbook 4 answers web american inspiration workbook 4 answers yubby june 23rd 2018 a bird in the bush a social history of birdwatching under the northern

american inspiration 4 workbook [][][] - Mar 12 2023

web american inspiration 4 workbook offering all the key benefits of inspiration to learners of american english plus a student cd rom packaged with the student s book key features as a student s book with eight units of four lessons each

american inspiration workbook 4 answers lasome - Jul 04 2022

web may 3 2023 american inspiration workbook 4 answers getting the books american inspiration workbook 4 answers now is not type of challenging means you could not unaided going taking into account ebook accretion or library or borrowing from your connections to read them this is an entirely easy means to specifically get guide by on

american inspiration 4 workbook yes24 - Jan 10 2023

web american inspiration is a motivating and sophisticated four level english course that takes teenage students from beginner to a high intermediate

4 american english file 4 wb answer key pdf pdf hail - Oct 19 2023

web workbook answer key american english file 4 ir tre page 4 1a questions and answers 1 grammar en a 3 where do you usually go on vacation ec 4 5 [] what happened at the meeting yesterday 6 [] ag 7 how long have you been learning english 8 [] gu room is 9 can you tell me where the bathroom 10 who are you waiting for b lan

american inspiration workbook 4 answers full pdf - Feb 11 2023

web american inspiration workbook 4 answers workbook answers white rose maths dec 02 2022 web workbook answers check your answers and use the video guidance if you need help autumn workbook answers autumn block 1 autumn block 2 autumn block 3 autumn block 4 autumn block 5 autumn block 6 answers block 1 year 1 answers

american inspiration 4 cd [][][] - Apr 13 2023

web american inspiration 4 cd offering all the key benefits of inspiration to learners of American English plus a student cd
rom packaged with the student's book key features a student's book with eight units of four lessons each

american inspiration four teens 3 pdf pdf scribd - Jul 16 2023

web american inspiration four teens 3 pdf free download as pdf file pdf or read online for free

american think answers respuestas del curso studocu - Sep 06 2022

web 1 he told me that he could help me 2 they said they would join us for lunch 3 i told you that i was going to be late 4 the article said the accident had happened the day before 5 our teacher told us she had lost our homework

american inspiration 4 workbook contestado motor busqueda - May 02 2022

web american english file 3 workbook answer bing pdf descarga american english file 3 workbook answer pdf american english file workbook answer bing american english file 4 workbook answers bing pdf descarga american english file 4 workbook answers pdf american english file workbook answers bing

american inspiration workbook 1 answers web mei edu - Feb 28 2022

web it is not something like the costs it's nearly what you compulsion currently this american inspiration workbook 1 answers as one of the most keen sellers here will entirely be in the midst of the best options to review respuestas workbook pdf answer key american jetstream

macmillan - Jun 15 2023

web macmillan

american inspiration workbook 4 answers pdf copy - Aug 17 2023

web americas and explains how to incorporate relevant resources into their curricula using a social justice lens this book begins with an overview of the Iberian impact on indigenous Americans and connects it to language teaching giving practical ideas that are tied to language learning standards

free american inspiration 4 macmillan cyberlab sutd edu sg - Aug 05 2022

web new inspiration level 4 workbook mar 23 2023 new inspiration takes all the best elements of the original course and adds some exciting new characteristics perfect for motivating and challenging teenage students macmillan school dictionary feb 16 2020 a student dictionary reflecting current American usage of 65 000 entries

workbook level 4 perspectives ngl sites - Nov 08 2022

web answer key workbook audio audio examview audio student book audio workbook communicative activities examview reading texts scripts student book audio script workbook audio script video script video word lists level 4 teacher's book answer keys answer key student book answer key workbook audio audio examview

american inspiration for teens 5 pdf english language - Sep 18 2023

web simple present or wil 1 we catch the bus if we run 2 lf you work hard you pass th e exam 3 they have a picnic tomorrow
if it be a nice day 4 lf 1 not hear from you 1 be worried 5 you stay in shape if you exerclse 6 lf